

**BEDIENUNG UND INSTALLATION  
OPERATION AND INSTALLATION  
UTILISATION ET INSTALLATION  
BEDIENING EN INSTALLATIE  
USO E INSTALLAZIONE  
BETJENING OG INSTALLATION  
OPERACIÓN E INSTALACIÓN**

Integralspeicher | Integral cylinder | Tour hydraulique combinée | Combiboiler |  
Caldaia integrale | Integralbeholdere | Acumuladores integrales

- » HSBC 180 Plus
- » HSBC 180 S Plus

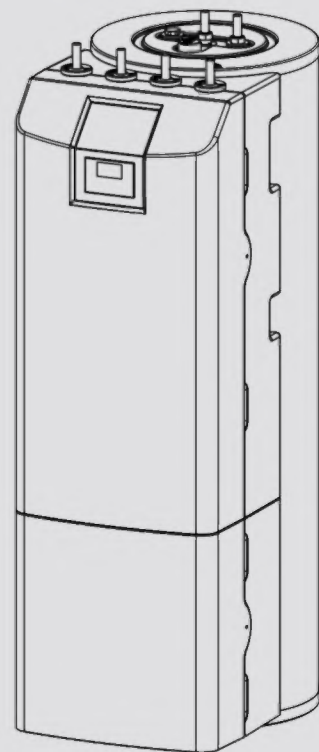

**STIEBEL ELTRON**

**SPECIAL INFORMATION**

**OPERATION**

<b>1. General information</b>	<b>29</b>
1.1 Relevant documents	29
1.2 Safety instructions	29
1.3 Other symbols in this documentation	29
1.4 Information on the appliance	29
1.5 Units of measurement	29
<b>2. Safety</b>	<b>30</b>
2.1 Intended use	30
2.2 General safety instructions	30
2.3 Test symbols	30
<b>3. Appliance compatibility</b>	<b>30</b>
<b>4. Appliance description</b>	<b>30</b>
<b>5. Settings</b>	<b>31</b>
<b>6. Cleaning, care and maintenance</b>	<b>31</b>
<b>7. Troubleshooting</b>	<b>31</b>

**INSTALLATION**

<b>8. Safety</b>	<b>32</b>
8.1 General safety instructions	32
8.2 Instructions, standards and regulations	32
<b>9. Appliance description</b>	<b>32</b>
9.1 Standard delivery	32
9.2 Accessories	32
<b>10. Preparation</b>	<b>32</b>
10.1 Installation site	32
10.2 Transport and handling	33
<b>11. Installation</b>	<b>34</b>
11.1 Positioning the appliance	34
11.2 Removing/fitting the front casing	34
11.3 Heating water connection and safety valve	34
11.4 DHW connection and safety assembly	36
11.5 Filling the system	36
11.6 Venting the appliance	37
<b>12. Electrical connection</b>	<b>37</b>
12.1 Electric emergency/booster heater and control voltage	38
12.2 Sensor installation	40
12.3 Remote control	40
<b>13. Commissioning</b>	<b>41</b>
13.1 Checks before commissioning the heat pump manager	41
13.2 Commissioning the heat pump manager	41
13.3 Wilo-Para .../Sc circulation pumps	42
13.4 Appliance handover	43
<b>14. Shutting down the system</b>	<b>43</b>
<b>15. Maintenance</b>	<b>43</b>
<b>16. Specification</b>	<b>44</b>
16.1 Dimensions and connections	44
16.2 Wiring diagram	46
16.3 Energy consumption data	50
16.4 Data table	50

**GUARANTEE | ENVIRONMENT AND RECYCLING**

**SPECIAL INFORMATION**

- The appliance may be used by children over 8 years of age and persons with reduced physical, sensory or mental capabilities or a lack of experience and expertise, provided that they are supervised or they have been instructed on how to use the appliance safely and have understood the potential risks. Children must never play with the appliance. Cleaning and user maintenance must not be carried out by children without supervision.
- The connection to the power supply must be in the form of a permanent connection. Ensure the appliance can be separated from the power supply by an isolator that disconnects all poles with at least 3 mm contact separation.
- Observe all applicable national and regional regulations and instructions.
- Observe minimum distances (see chapter “Installation / Preparations / Installation site”).
- Only a qualified contractor should carry out installation, commissioning, maintenance and repair of the appliance.

**DHW cylinder**

- Drain the appliance as described in chapter “Installation / Maintenance / Draining the DHW cylinder”.
- Observe the maximum permissible pressure (see chapter “Installation / Specification / Data table”).
- The appliance is pressurised. During the heat-up process, expansion water will drip from the safety valve.
- Regularly activate the safety valve to prevent it from becoming blocked, e.g. by limescale deposits.
- The safety valve drain aperture must remain open to atmosphere.

# OPERATION

## 1. General information

The chapters “Special information” and “Operation” are intended for appliance users and qualified contractors.

The chapter “Installation” is intended for qualified contractors.



**Note**  
Read these instructions carefully before using the appliance and retain them for future reference.  
Pass on these instructions to a new user if required.

### 1.1 Relevant documents

- Operating and installation instructions for the WPM heat pump manager
- Operating and installation instructions for the connected heat pump
- Operating and installation instructions for all other system components

### 1.2 Safety instructions

#### 1.2.1 Structure of safety instructions



**KEYWORD Type of risk**  
Here, possible consequences are listed that may result from failure to observe the safety instructions.  
► Steps to prevent the risk are listed.

#### 1.2.2 Symbols, type of risk

Symbol	Type of risk
	Injury
	Electrocution
	Burns (burns, scalding)

#### 1.2.3 Keywords

KEYWORD	Meaning
DANGER	Failure to observe this information will result in serious injury or death.
WARNING	Failure to observe this information may result in serious injury or death.
CAUTION	Failure to observe this information may result in non-serious or minor injury.

### 1.3 Other symbols in this documentation



**Note**  
General information is identified by the adjacent symbol.  
► Read these texts carefully.

Symbol	Meaning
	Material losses (appliance damage, consequential losses and environmental pollution)
	Appliance disposal

► This symbol indicates that you have to do something. The action you need to take is described step by step.

□ □ ■ These symbols show you the software menu level (in this example level 3).

### 1.4 Information on the appliance

#### Connections

Symbol	Meaning	
	Inlet / intake	Red arrow: hot Blue arrow: Cold Green arrow: Neutral
	Drain / outlet	Red arrow: hot Blue arrow: Cold Green arrow: Neutral
	Domestic hot water	
	DHW circulation	
	Heat pump	
	Heating	

### 1.5 Units of measurement



**Note**  
All measurements are given in mm unless stated otherwise.

## 2. Safety

### 2.1 Intended use

The appliance is used for heating and seasonal cooling of rooms and for DHW heating. For sub dew point cooling, CDT 180 condensate pump and condensate pan accessories must be used. With the CDT 180 accessories, cooling rooms is only permissible with monitoring of the dew point. Sub dew point cooling is only ever permissible on a seasonal basis with a subsequent heating period.

The appliance is intended for domestic use. It can be used safely by untrained persons. The appliance can also be used in non-domestic environments, e.g. in small businesses, as long as it is used in the same way.

Any other use beyond that described shall be deemed inappropriate. Observation of these instructions and of the instructions for any accessories used is also part of the correct use of this appliance.

### 2.2 General safety instructions



#### WARNING Burns

There is a risk of scalding at outlet temperatures in excess of 43 °C.



#### WARNING Injury

The appliance may be used by children over 8 years of age and persons with reduced physical, sensory or mental capabilities or a lack of experience and expertise, provided that they are supervised or they have been instructed on how to use the appliance safely and have understood the potential risks. Children must never play with the appliance. Cleaning and user maintenance must not be carried out by children without supervision.



#### WARNING Injury

For safety reasons, only operate the appliance with the front casing closed.



#### Note

The DHW cylinder is under supply pressure. During the heat-up process, expansion water will drip from the safety valve.

► If water continues to drip when heating is completed, please inform your qualified contractor.

### 2.3 Test symbols

See type plate on the appliance.

## 3. Appliance compatibility

The appliance can be operated in conjunction with the following air source heat pumps:

- WPL-A 05/07 HK 230 Premium
- WPL 07-17 ACS classic
- HPA-O 05.1/07.1 CS Premium
- HPA-O 3-8 CS Plus

## 4. Appliance description

The buffer cylinder and DHW cylinder with indirect coil are arranged one on top of the other.

The appliance has a plastic jacket with foam insulation and is equipped with a removable front casing. The appliance is connected hydraulically and electrically to the heat pump. All hydraulic connections are made at the top.

In addition to the DHW cylinder and the buffer cylinder, further system components are integrated:

- Heat pump manager
- Cylinder primary pump
- Highly efficient circulation pump for a heating circuit without mixer
- Multifunction assembly with safety valve, 3-way diverter valve and emergency/booster heater for mono energetic operation

### DHW cylinder

The steel cylinder is equipped with special directly applied enamel coating on the inside and a sacrificial anode. The sacrificial anode protects the cylinder interior from corrosion.

The heating water heated by the heat pump is pumped through an indirect coil inside the DHW cylinder. The heat channelled through the indirect coil is thus transferred to the domestic hot water. The integral heat pump manager regulates the DHW heating to the required temperature.

### Buffer cylinder

The steel cylinder provides hydraulic separation between the flow rates of heat pump and heating circuit. The heating water heated by the heat pump is transferred into the buffer cylinder by the cylinder charging pump. When a demand is issued, the integral heating circuit pump delivers the heating water to the heating circuit.

### Heat pump manager (WPM)

The system is controlled by means of the integral heat pump manager.

The heat pump manager is suitable for the control of a direct heating circuit and a heating circuit with mixer.

You can set the times and temperatures for heating operation and heating DHW. Remote controls for controlling the direct heating circuit and the heating circuit with mixer are available as accessories.

For detailed information, see the enclosed operating and installation instructions for the WPM heat pump manager.

# OPERATION

## Settings

### Multifunction assembly (MFG)

3-way diverter valve: The multifunction assembly switches between heating circuit and DHW heating.

Safety valve: When the pressure is high, the safety valve opens to relieve the pressure in the system.

Air vent valve: Components are vented through air vent valves, e.g. pipes or indirect coil.

Emergency/booster heater: in standard mode, the emergency/booster heater can support the heat pump in mono energetic mode below the dual mode point. Depending on the setting and connected heat pump, the emergency/booster heater can also be used to back up DHW heating or in pasteurisation mode. In the event of a heat pump malfunction, the emergency/booster heater can temporarily ensure DHW heating and the heating of rooms.

## 5. Settings



### Material losses

The system's active frost protection is not guaranteed if the power supply is interrupted.

- ▶ Never interrupt the power supply even outside the heating season.



### Note

The heat pump manager has an automatic summer/winter changeover so you can leave the system switched on in summer.

The system is controlled by means of the integral heat pump manager. Please observe the heat pump manager operating and installation instructions.

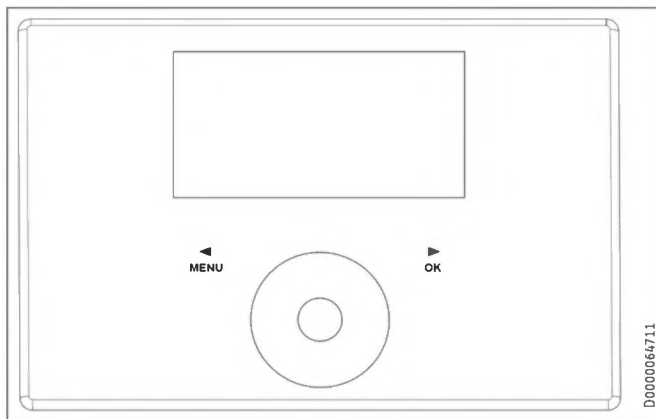

## 6. Cleaning, care and maintenance

- ▶ Have the electrical safety of the appliance and the function of the safety assembly regularly checked by a qualified contractor.
- ▶ Have the sacrificial anode checked by a qualified contractor after the first two years of use. The qualified contractor will then determine the intervals at which the sacrificial anode should be checked.
- ▶ Never use abrasive or corrosive cleaning agents. A damp cloth is sufficient for cleaning the unit.

## 7. Troubleshooting

Problem	Cause	Remedy
The water does not heat up. The heating does not work.	There is no power.	Check the fuses / MCBs in your fuse box / distribution board.

Observe the information about troubleshooting in other applicable documents (see chapter "Other applicable documents").

If you cannot remedy the fault, contact your qualified contractor. To facilitate and speed up your enquiry, please provide the serial number from the type plate (000000-0000-000000).

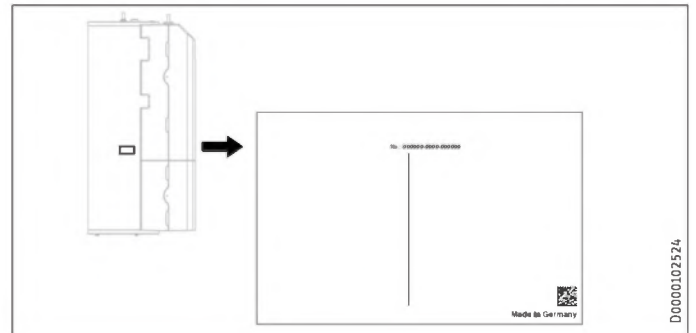

# INSTALLATION

## 8. Safety

Only a qualified contractor should carry out installation, commissioning, maintenance and repair of the appliance.

### 8.1 General safety instructions

We guarantee trouble-free function and operational reliability only if original accessories and spare parts intended for the unit are used.

### 8.2 Instructions, standards and regulations



#### Note

Observe all applicable national and regional regulations and instructions.

## 9. Appliance description

### 9.1 Standard delivery

The following are delivered with the appliance:

- Operating and installation instructions for the WPM heat pump manager
- Outside temperature sensor AF PT
- 3 adjustable feet
- Drain hose
- DHW circulation line and flat gasket union nut

### 9.2 Accessories

#### Required accessories

Safety assemblies and pressure reducing valves are available to suit the prevailing supply pressure. These type-tested safety assemblies protect the appliance against impermissible excess pressure.

Required for area cooling:

- Pt1000 temperature sensor
- FET remote control

#### Additional accessories

- Remote control for heating operation
- High limit safety cut-out STB-FB
- Water softening fitting HZEA
- CDT 180 condensate pump and condensate pan (required for continuous cooling without dew point monitoring)

## 10. Preparation

### 10.1 Installation site



#### Material losses

Never install the appliance in wet rooms.

Install the appliance near the draw-off point in a dry room free from the risk of frost. To reduce line losses, keep the distance short between the appliance and the heat pump.

Ensure the floor has sufficient load bearing capacity and evenness (for weight, see chapter "Specification / Data table").

The room must not be subject to a risk of explosions arising from dust, gases or vapours.

If you are installing the appliance in a boiler room together with other heating equipment, ensure that the operation of the other heating equipment will not be impaired.

#### Minimum clearances

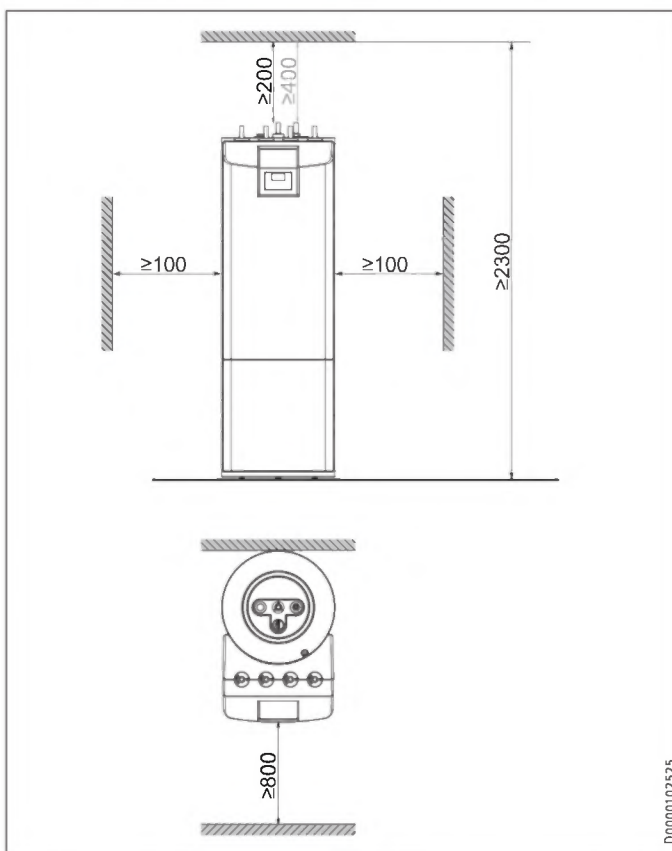

Minimum ceiling clearance: Without DHW circulation 200 mm, with DHW circulation 400 mm.

- Maintain the minimum clearances to ensure trouble-free operation of the appliance and facilitate maintenance work.

# INSTALLATION

## Preparation

### 10.2 Transport and handling



#### Material losses

- ▶ Store and transport the appliance at temperatures between -20 °C and +60 °C.



#### Note

- Two people are required when installing the adjustable feet and transporting the appliance.

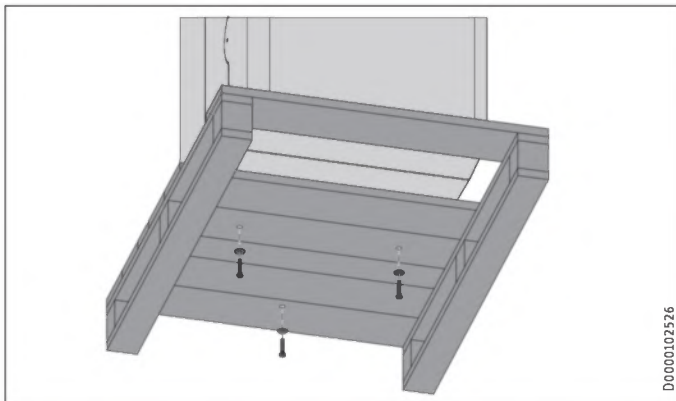

D0000102526

- ▶ Undo the 3 screws on the non-returnable pallet.



#### Material losses

- Never roll the appliance over the edge of the pallet.

### Installing supplied carrying straps and adjustable feet



#### Note

- The carrying straps are intended for one-time use to manoeuvre the appliance.

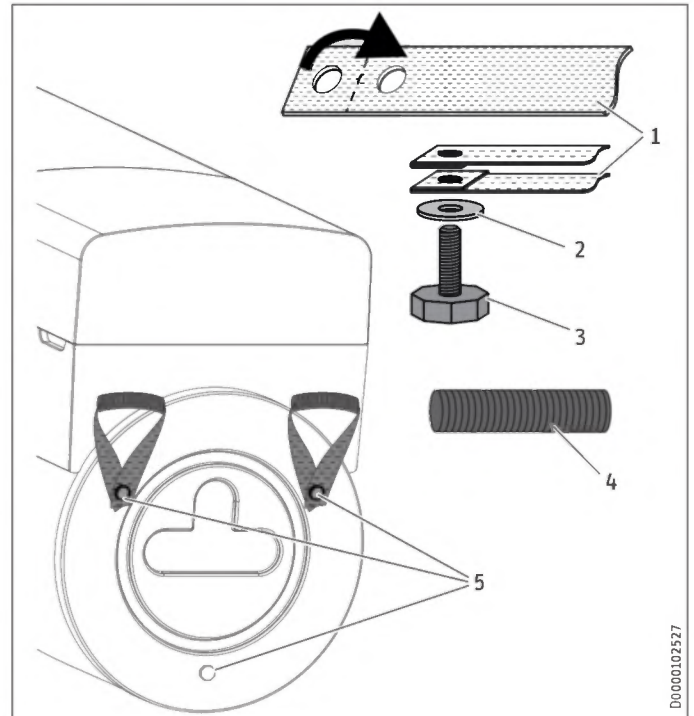

D0000102527

- 1 Carrying strap
- 2 Washer
- 3 Adjustable foot
- 4 Pipe
- 5 Threaded hole

- ▶ Slide a pipe over one carrying strap.
- ▶ Fold the end of the carrying strap with the two holes and insert an adjustable foot with washers into the carrying strap, as shown in the figure.
- ▶ Tilt the appliance.
- ▶ Screw the adjustable foot with the carrying strap into one of the threaded holes (shown in the figure) in the appliance base.
- ▶ Fit the second carrying strap likewise.
- ▶ Screw an adjustable foot without a carrying strap into the threaded hole in the appliance base.

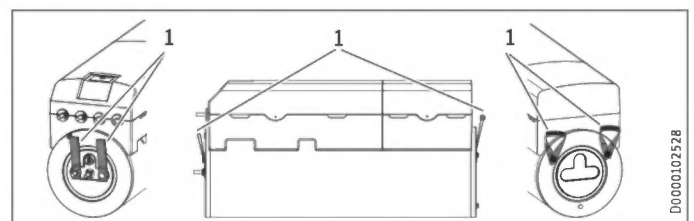

D0000102528

- 1 Carrying straps

# INSTALLATION

## Installation



### Material losses

Always carry the appliance by the carrying straps. Never transport the appliance using a hoist. During transportation, never subject the pipe connectors to any strain. Protect the appliance against heavy impact during transport.

- ▶ Lift the appliance off the pallet by the carrying straps.
- ▶ After transportation, tuck the lower carrying straps under the appliance. You can also cut off the upper and lower carrying straps.

## 11. Installation

### 11.1 Positioning the appliance

- ▶ When positioning the appliance, observe minimum clearances (see chapter "Preparations / Installation site").
- ▶ Use the adjustable feet to compensate for any unevenness in the floor.

### 11.2 Removing/fitting the front casing

#### Removing the front casing



### Material losses

If you remove the front panel from the appliance at an angle or unevenly, you may damage it.

- ▶ Remove the front panel from the appliance by pulling it evenly and in a straight line.

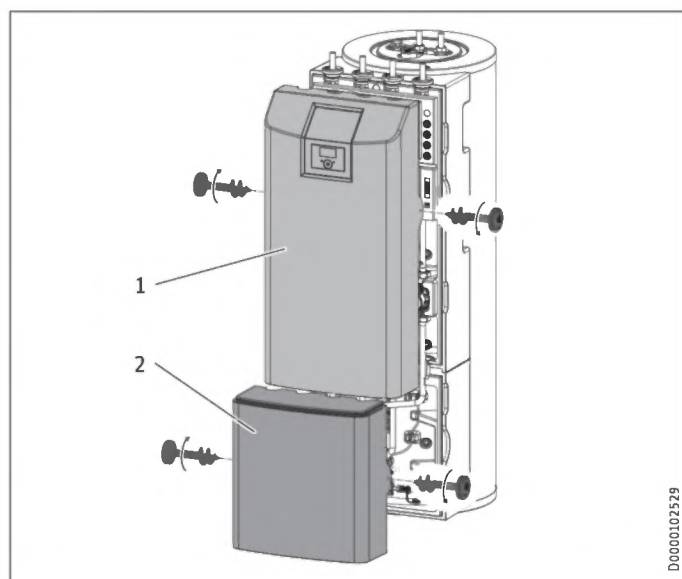

- 1 Upper front panel
- 2 Lower front panel

- ▶ Remove the screws on the left and right of the upper front panel.
- ▶ Carefully pull the upper front panel forwards to remove it from appliance and store it securely so that it cannot tip over, without putting strain on the cable connections.

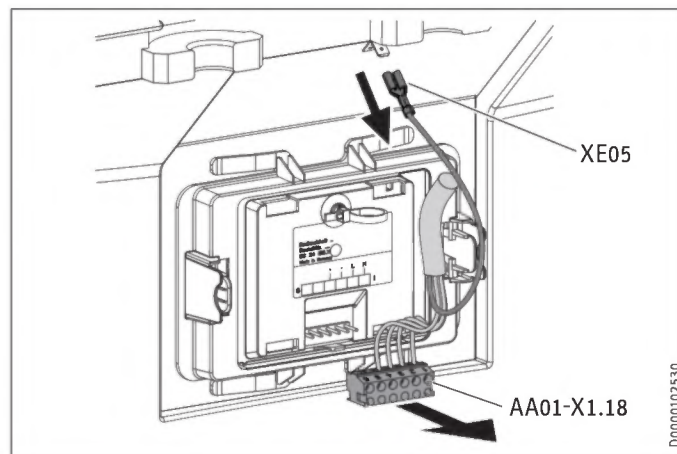

- ▶ To be able to store the upper front panel at a distance from the appliance, loosen the cable tie, unplug the connector from the electronic assembly for operation (AA01-X1.18) and the earth (XE05) at the heat pump manager and store the front panel securely so that it cannot tip over.
- ▶ Remove the screws on the left and right of the lower front panel.
- ▶ Pull the lower front panel forwards and store it securely so that it cannot tip over.

#### Fitting the front casing

Fit the front casing in reverse order. Take care to position the connection lines correctly and not to pinch any cables.

### 11.3 Heating water connection and safety valve

#### 11.3.1 Safety instructions



### Material losses

The heating system to which the appliance is connected must be installed by a qualified contractor in accordance with the water installation drawings in the technical guides.



### Material losses

When fitting additional shut-off valves, install a further safety valve in an accessible location on the heat generator itself or in the flow line in close proximity to the heat generator.

There must not be a shut-off valve between the heat generator and the safety valve.



### Note

The use of non-return valves in the charging circuits between the heat generator and the buffer or DHW cylinder can impair the function of the integral multifunction assembly (MFG) and lead to faults in the heating system.

- ▶ Only use our standard hydraulic solutions for the installation of the appliances.

# INSTALLATION

## Installation

### Oxygen diffusion



#### Material losses

Avoid open vented heating systems and underfloor heating systems with plastic pipes that are permeable to oxygen.

In underfloor heating systems with plastic pipes that are permeable to oxygen and in open vented heating systems, oxygen diffusion may lead to corrosion on the steel components of the heating system (e.g. on the indirect coil of the DHW cylinder, on buffer cylinders, steel radiators or steel pipes).



#### Material losses

The products of corrosion (e.g. rusty sludge) can settle in the heating system components, which may result in a lower output or fault shutdowns due to reduced cross-sections.

### Supply lines

- ▶ The maximum permissible line length between the appliance and the heat pump will vary, depending on the version of the heating system (pressure drop). As a standard value, assume a maximum line length of 10 m and a pipe diameter of 22-28 mm.
- ▶ Protect the flow and return lines against frost with sufficient thermal insulation.
- ▶ Also protect all supply lines against humidity, damage and UV radiation by means of a conduit.
- ▶ Connect the hydraulic connections with flat gaskets.

### Pressure differential

If the available external pressure difference is exceeded, the pressure drop in the heating system could result in a reduced heating output.

- ▶ When sizing the pipes, ensure that the available external pressure differential is not exceeded (see chapter "Specification / Data table").
- ▶ When calculating the pressure drop, take account of the flow and return lines and the pressure drop of the heat pump. The pressure drop must be covered by the available pressure differential.

### 11.3.2 Heating water connection

Installation example:

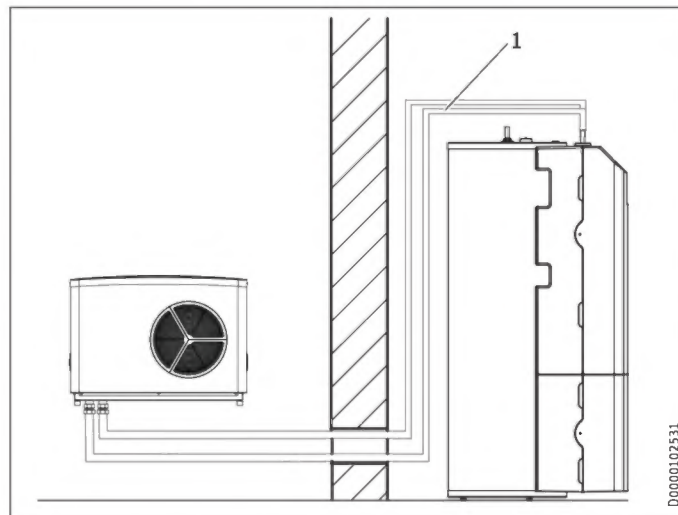

#### 1 Pipes carrying heating water

- ▶ Thoroughly flush the pipes before connecting the heat pump. Foreign bodies (e.g. welding pearls, rust, sand, sealant, etc.) can impair the operational reliability of the heat pump.
- ▶ Install the heating water pipes (see chapter "Specification / Dimensions and connections").

### Safety valve drain hose

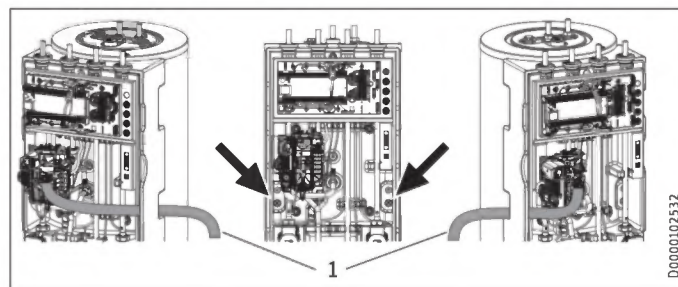

#### 1 Safety valve drain hose

- ▶ Unroll the safety valve drain hose connected to the multi-function assembly.
- ▶ On one of the lower prepared openings on the left or right, remove just enough insulating material as necessary for the drain hose, in order to minimise the exchange of air.
- ▶ Route the drain hose through the prepared opening from the appliance.
- ▶ Route the drain hose with a constant fall to a drain.
- ▶ Ensure that the drain hose is open to the outside.
- ▶ Secure the drain hose above the drain to prevent any hose movement in the event of water being discharged.



#### Material losses

Route the drain hose to a drain to enable water to drain freely when the safety valve is open.

# INSTALLATION

## Installation

### 11.4 DHW connection and safety assembly

#### 11.4.1 Safety instructions

**Material losses**  
The maximum permissible pressure must not be exceeded (see chapter "Specification / Data table").

**Material losses**  
Operate the appliance only with pressure-tested taps.

**Note**  
The use of non-return valves in the charging circuits between the heat generator and the buffer or DHW cylinder can impair the function of the integral multifunction assembly (MFG) and lead to faults in the heating system.  
▶ Only use our standard hydraulic solutions for the installation of the appliances.

#### Cold water line

Galvanised steel, stainless steel, copper and plastic are approved materials.

**Material losses**  
A safety valve is required.

#### DHW line, DHW circulation line

Stainless steel, copper and plastic are approved materials.

#### 11.4.2 Fitting the DHW circulation line (optional)

A DHW circulation line with external DHW circulation pump can be fitted to the "DHW circulation" connection (see chapter "Specification / Dimensions and connections").

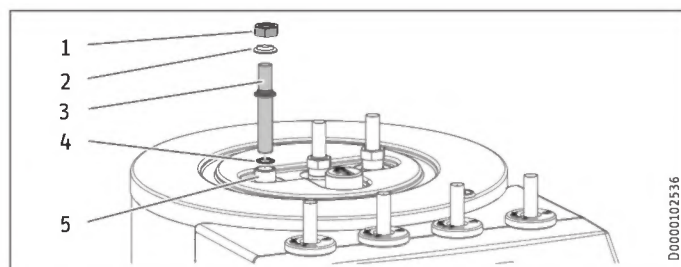

- 1 Union nut
- 2 Insulating sleeve
- 3 DHW circulation line
- 4 Gasket
- 5 "DHW circulation" connection

- ▶ Remove the sealing cap from the DHW circulation connection (see chapter "Specification / Dimensions and connections").
- ▶ Connect the DHW circulation line with the gasket, the insulating bushing and the flat gasket union nut.

#### 11.4.3 DHW connection and safety assembly

- ▶ Flush the pipes thoroughly.
- ▶ Install the DHW outlet line and the cold water inlet line (see chapter "Specification / Dimensions and connections"). Connect the hydraulic connections.

- ▶ Install a type-tested safety valve in the cold water supply line. Please note that, depending on the supply pressure, you may also need a pressure reducing valve.
- ▶ Size the drain pipe so that water can drain off unimpeded when the safety valve is fully opened.
- ▶ The safety valve drain aperture must remain open to atmosphere.
- ▶ Install the safety valve drain pipe with a constant fall to the drain.

### 11.5 Filling the system

#### Heating circuit water quality

Carry out a fill water analysis before filling the system. This analysis may, for example, be requested from the relevant water supply utility.

To avoid damage as a result of scaling, it may be necessary to soften or desalinate the fill water. The fill water limits specified in chapter "Specification / Data table" must always be observed.

- ▶ Recheck these limits 8-12 weeks after commissioning and during the annual system service.

**Material losses**  
Never switch on the power before filling the system.

**Note**  
With a conductivity >1000 µS/cm, desalination treatment is recommended in order to avoid corrosion.

**Note**  
If you treat the fill water with inhibitors or additives, the same limits apply as for desalination.

**Note**  
Suitable appliances for water softening, as well as for filling and flushing heating systems, can be obtained via trade suppliers.

**Note**  
The appliance offers frost protection for the connection lines in regular operation.

In the event of prolonged power failure or when shutting down, drain the DHW side of the appliance.

If it is not possible to detect power failures (for example if the system is in a holiday home left vacant for extended periods of time), the following protective measure can be taken.

- ▶ Add a suitable concentration of ethylene glycol to the fill water. (20-40 % by vol.)
- ▶ Please note that antifreeze changes the density and viscosity of the fill water.

		Part number
MEG 10	Heat transfer medium as concentrate on an ethylene glycol base	231109
MEG 30	Heat transfer medium as concentrate on an ethylene glycol base	161696

# INSTALLATION

## Electrical connection

### 11.5.1 Filling the heating system



**Note**

Fill the heating system exclusively via the lower drain & fill valve on the buffer cylinder.

In the delivered condition, the 3-way diverter valve of the multifunction assembly is in its centre position, so that the heating circuit and the heat exchanger for DHW heating are filled evenly. When power is switched on, the 3-way diverter valve automatically switches to heating mode.

To fill or drain the system later, you must first place the 3-way diverter valve into its centre position.

To set the heat pump manager:

- ▶ With the MENU key, call up the main menu.
- ▶ Select the menu or value and confirm with OK:

- DIAGNOSIS
- ■ RELAY TEST SYSTEM
- □ ■ DRAIN HYD

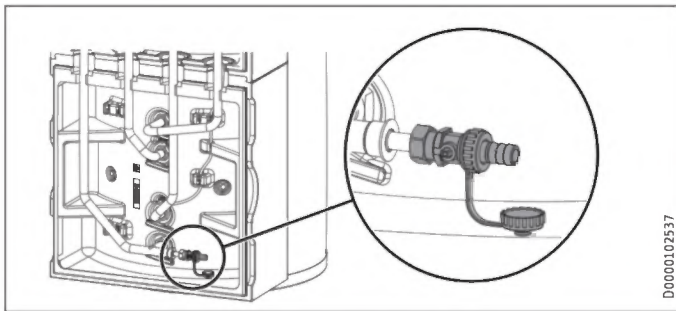

- ▶ Fill the heating system via the lower drain & fill valve on the buffer cylinder.
- ▶ Vent the pipework.

### 11.5.2 DHW cylinder filling

- ▶ Fill the DHW cylinder via the cold water connection.
- ▶ Open all downstream draw-off valves until the appliance is full and the pipework is free of air.
- ▶ Adjust the flow rate. For this, observe the maximum permissible flow rate with a fully opened tap (see chapter "Specification / Data table"). If necessary reduce the flow rate at the butterfly valve of the safety assembly.
- ▶ Carry out a tightness check.
- ▶ Check the safety valve.

### 11.6 Venting the appliance

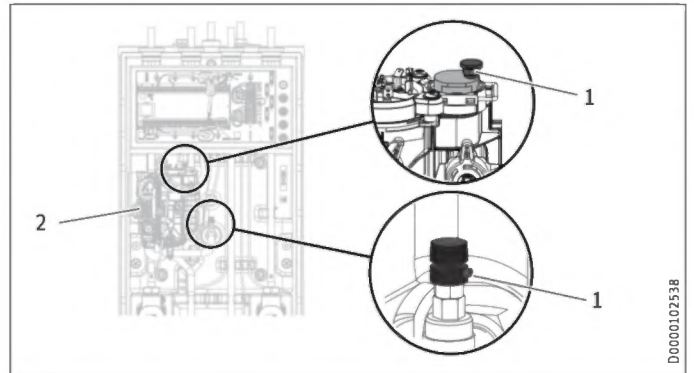

- 1 Air vent valve
- 2 PCB
- ▶ Vent the pipework and indirect coil by pulling up the red cap on the air vent valves.
- ▶ Close the air vent valves after the venting process.



**Material losses**  
Close the air vent valves again after venting.

## 12. Electrical connection



**WARNING Electrocutation**  
Carry out all electrical connection and installation work in accordance with relevant regulations.  
▶ Before any work on the appliance, disconnect all poles from the power supply.



**WARNING Electrocutation**  
The connection to the power supply must be in the form of a permanent connection. Ensure the appliance can be separated from the power supply by an isolator that disconnects all poles with at least 3 mm contact separation. This requirement can be met by using contactors, circuit breakers, fuses/MCBs, etc.



**Material losses**  
Provide separate fuses for the two power circuits of the appliance and the control unit.



**Material losses**  
Provide separate fuses/MCBs for the two power circuits, i.e. for the compressor and the electric emergency/booster heater circuits.



**Material losses**  
Observe the type plate. The specified voltage must match the mains power supply.



**Note**  
You must have permission to connect the appliance from the relevant power supply utility.

## Electrical connection

The terminal box of the appliance is located behind the front casing (see chapter “Preparations / Transport and handling / Removing/ fitting the front casing”).

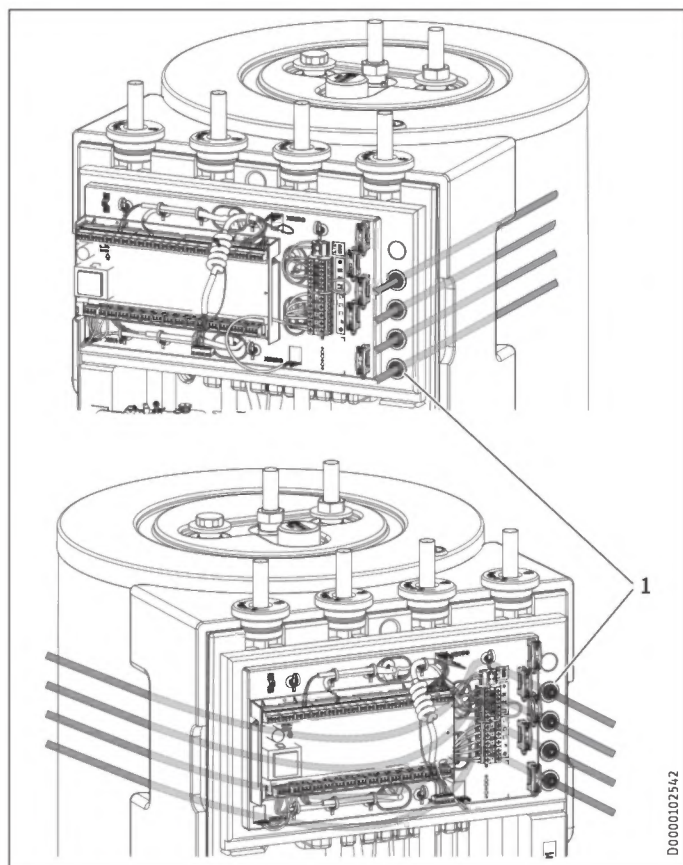

### 1 Cable entry plugs

- ▶ Cut the 4 cable entry plugs only as much as required for the cable diameter in order to minimise the exchange of air.
- ▶ Route all power supply cables and sensor leads into the appliance through the cable entry from the left or right. From the left, route the cables behind the terminal box to the right-hand side. Lay the lines on the right-hand side through the empty conduits and cable entry plugs.
- ▶ Connect the power cables and sensor leads as detailed below.

Install cables with the following cross-sections in accordance with the respective fuse protection:

Fuse protection	Assignment	Cable cross-section
B 16 A	Electric emergency/booster heater (DHC) Three-phase	2.5 mm <sup>2</sup> 1.5 mm <sup>2</sup> with only two live wires, routing according to applicable regulations
B 16 A	Electric emergency/booster heater (DHC) Single phase	2.5 mm <sup>2</sup> 1.5 mm <sup>2</sup> when routing a multi-core cable on a wall or in an electrical conduit on a wall
B 16 A	Control unit	1.5 mm <sup>2</sup>

## 12.1 Electric emergency/booster heater and control voltage

Appliance function	Effect of the electric emergency/booster heater
Mono energetic operation	If the dual mode point is undershot, the electric emergency/booster heater safeguards both the heating operation and the provision of high DHW temperatures.
Emergency mode	Should the heat pump suffer a fault that prevents its continued operation, the heating output will be covered by the electric emergency/booster heater.

### HSBC 180 Plus: Electrical connection three-phase

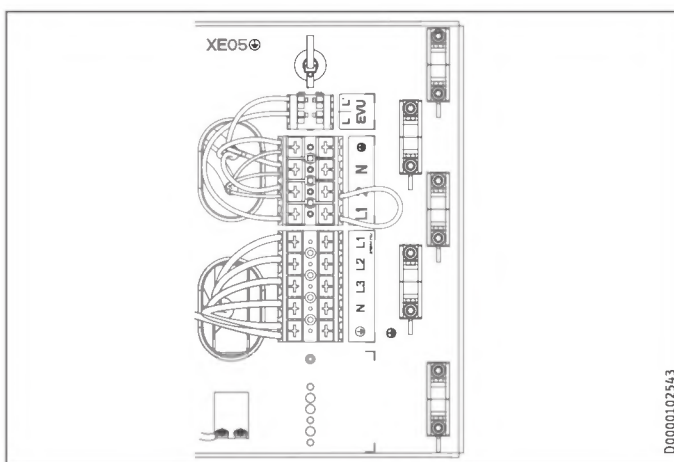

### XD02 Electric emergency/booster heater (DHC)

Connected Load	Terminal assignment
2,9 kW	PE N L1
5,9 kW	PE N L2 L1
8,8 kW	PE N L3 L2 L1

- ▶ Connect the electrical emergency/booster heater with the desired rating as detailed in the table.

# INSTALLATION

## Electrical connection

### HSBC 180 S Plus: Electrical connection single phase

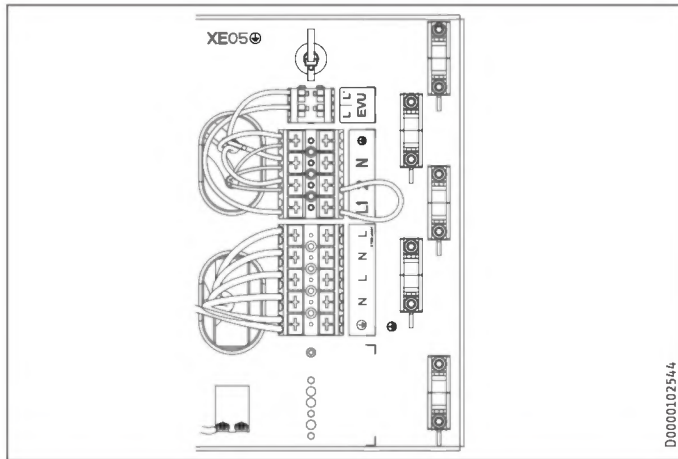

#### XD02 Electric emergency/booster heater (DHC)

Connected load	Cable cross-section	Terminal assignment		
2,9 kW	2.5 mm <sup>2</sup>	PE	N	L
5,9 kW	2.5 mm <sup>2</sup>	PE	N	L
	2.5 mm <sup>2</sup>	PE	N	L

► Connect the cables for the electrical emergency/booster heater with the desired rating as in the table.

#### Control voltage



#### Material losses

► Only connect energy efficient circulation pumps approved by us to the pump connections.

#### XD01.2 Heat pump enable signal

EVU	Enable signal, bus cable to the WPM screened with strain relief in terminal.
-----	--

#### Heat pump manager terminal assignment



#### WARNING Electrocutation

Only components that operate with safety extra low voltage (SELV) and that ensure secure separation from the mains voltage supply may be connected to the low voltage terminals of the appliance. Connecting other components can make parts of the appliance and connected components live.

► Only use components which have been approved by us.

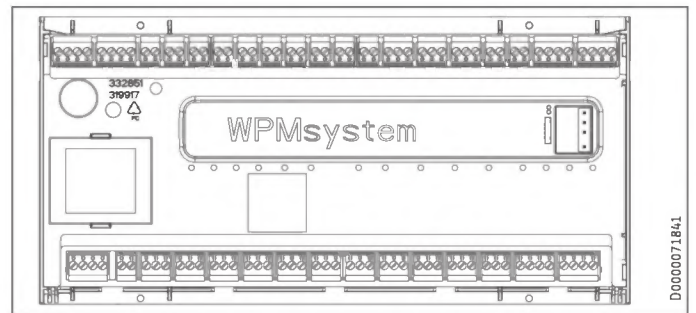

#### Safety extra low voltage

X1.1	+	+	CAN (connection for heat pump and WPE heat pump extension)
CAN A	-	-	
	L	L	
	H	H	
X1.2	+	+	CAN (connection for FET remote control and ISG Internet Service Gateway)
CAN B	-	-	
	L	L	
	H	H	
X1.3	Signal	1	Outside sensor
	Earth	2	
X1.4	Signal	1	Buffer sensor (heating circuit sensor 1)
	Earth	2	
X1.5	Signal	1	Flow sensor
	Earth	2	
X1.6	Signal	1	Heating circuit sensor 2
	Earth	2	
X1.7	Signal	1	Heating circuit sensor 3
	Earth	2	
X1.8	Signal	1	DHW cylinder sensor
	Earth	2	
X1.9	Signal	1	Source sensor
	Earth	2	
X1.10	Signal	1	2nd heat generator (2.WE)
	Earth	2	
X1.11	Signal	1	Cooling flow
	Earth	2	
X1.12	Signal	1	DHW circulation sensor
	Earth	2	
X1.13	Signal	1	FE7 remote control / telephone remote switch / heating curve optimisation / SG Ready
	Earth	2	
	Signal	3	
X1.14	Constant 12 V	+	Analogue input 0-10 V
	Input	IN	
	GND	↓	
X1.15	Constant 12 V	+	Analogue input 0-10 V
	Input	IN	
	GND	↓	
X1.16	Signal	1	PWM output 1
	Earth	2	
X1.17	Signal	1	PWM output 2
	Earth	2	
X1.18	+	+	CAN (FES)
CAN B	-	-	
	L	L	
	H	H	
X1.19	+	+	CAN (connection for heat pump and WPE heat pump extension)
CAN A	-	-	
	L	L	
	H	H	

#### Mains power supply

X2.1	L	L	Power supply
	L	L	
	N	N	
	PE	⊕	
X2.2	L' (power supply utility input)	L'	L' (power supply utility input)
	L* (pumps L)	L* (pumps L)	L* (pumps L)

Mains power supply			
X2.3	L N PE	L N ⊕ PE	Heating circuit pump 1
X2.4	L N PE	L N ⊕ PE	Heating circuit pump 2
X2.5	L N PE	L N ⊕ PE	Heating circuit pump 3
X2.6	L N PE	L N ⊕ PE	Buffer charging pump 1
X2.7	L N PE	L N ⊕ PE	Buffer charging pump 2
X2.8	L N PE	L N ⊕ PE	DHW charging pump
X2.9	L N PE	L N ⊕ PE	Source pump / defrost
X2.10	L N PE	L N ⊕ PE	Fault output
X2.11	L N PE	L N ⊕ PE	DHW circulation pump / 2nd heat source DHW
X2.12	L N PE	L N ⊕ PE	2nd heat source heating
X2.13	L N PE	L N ⊕ PE	Cooling
X2.14	Mixer OPEN N PE Mixer CLOSE	▲ N ⊕ PE ▼	Not assigned
X2.15	Mixer OPEN N PE Mixer CLOSE	▲ N ⊕ PE ▼	Not assigned



### Note

For every appliance fault, output X2.10 issues a 230 V signal.

In the case of temporary faults, the output switches the signal through for a specific time.

In the case of faults that result in a permanent appliance shutdown, the output switches through permanently.

### Accessories, STB-FB high limit safety cut-out for underfloor heating systems (optional)

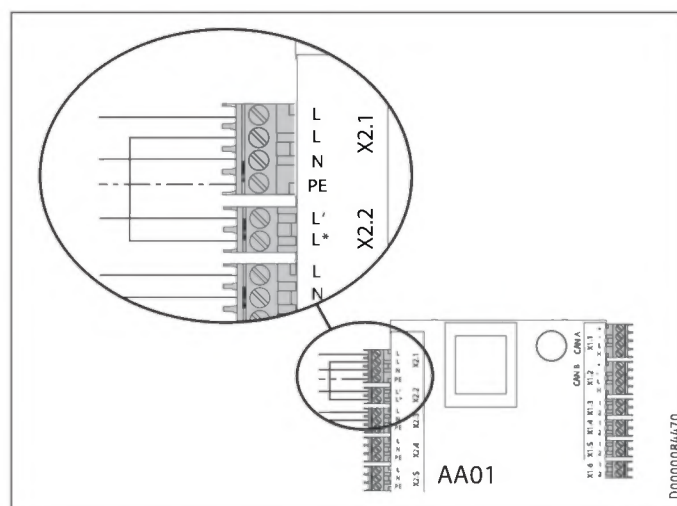

- ▶ Remove the jumper at AA01 between X2.1 (L) and X2.2 (L\*).
- ▶ Connect the STB-FB high limit safety cut-out to AA01 between X2.1 (L) and X2.2 (L\*).

## 12.2 Sensor installation

### 12.2.1 Outside temperature sensor AF PT

The outside temperature sensors have a significant influence on the function of your heating system. Therefore ensure that the outside temperature sensors are correctly positioned and well insulated.

- Install the outside temperature sensor on a north or north-eastern wall.
- Ensure that the outside temperature sensor is freely exposed to the elements but not placed in direct sunlight.
- Never mount the outside temperature sensor above windows, doors or air ducts.
- Observe the following minimum clearances: 2.5 m above the ground and 1 m to the side of windows and doors

### Installation

- ▶ Remove the cover.
- ▶ Secure the base with the screw supplied.
- ▶ Connect the cable.
- ▶ Connect the outside temperature sensor to AA01-X1.3.
- ▶ Replace the cover. The cover must audibly click into place.

### 12.3 Remote control

- ▶ Please observe the commissioning instructions for the heat pump manager.

The FET remote control is required to record humidity in the case of cooling via an area heating system.

### 13. Commissioning

Our customer support can assist with commissioning, which is a chargeable service.

If the appliance is intended for commercial use, observe the rules of the relevant Health & Safety at Work Act during commissioning. For further details, check with your local authorising body (in Germany, for example, this is the TÜV).

#### 13.1 Checks before commissioning the heat pump manager



##### Material losses

Observe the maximum system temperature in underfloor heating systems.

- ▶ Check that the heating system is filled to the correct pressure and the quick-action air vent valve is closed.
- ▶ Check whether the outside temperature sensor is correctly placed and connected.
- ▶ Check whether the power supply is connected correctly.
- ▶ Check whether the signal cable to the heat pump (bus cable) is correctly connected.

#### High limit safety cut-out



##### Note

At temperatures below  $-15\text{ }^{\circ}\text{C}$  the high limit safety cut-out may respond. The appliance may be subjected to these temperatures during storage or transport.

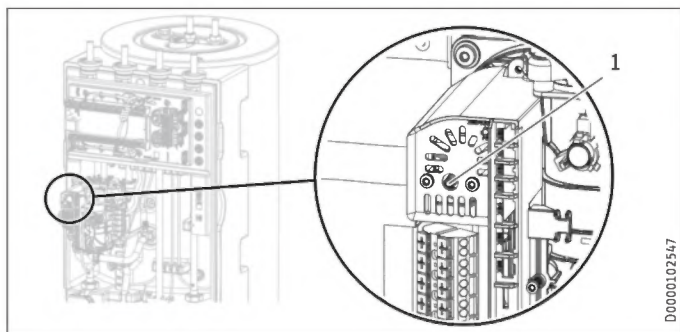

1 High limit safety cut-out reset button

- ▶ Check whether the high limit safety cut-out has tripped.
- ▶ If the high limit safety cut-out has triggered, reset it with the reset button.

#### 13.2 Commissioning the heat pump manager

Commission the heat pump manager and make all settings in accordance with the heat pump manager operating and installation instructions.



##### Note

For DHW mode, ensure that the PARALLEL OPERATION option is set in the heat pump manager. With this setting the primary pump is also active in DHW mode.

To set the heat pump manager:

- ▶ With the MENU key, call up the main menu.
- ▶ Select the menu or value and confirm with OK:

SETTINGS	Value
<input type="checkbox"/> <input checked="" type="checkbox"/> DHW	
<input type="checkbox"/> <input checked="" type="checkbox"/> STANDARD SETTING	
<input type="checkbox"/> <input type="checkbox"/> <input checked="" type="checkbox"/> DHW MODE	PARALLEL OPERATION



##### Note

On appliances with a single phase connection, set the heat pump manager as follows for calculating the amount of heat.

To set the heat pump manager:

- ▶ With the MENU key, call up the main menu.
- ▶ Select the menu or value and confirm with OK:

SETTINGS	Value
<input type="checkbox"/> <input checked="" type="checkbox"/> HEATING	
<input type="checkbox"/> <input checked="" type="checkbox"/> ELECTRIC BOOSTER HEATER	
<input type="checkbox"/> <input type="checkbox"/> <input checked="" type="checkbox"/> NUMBER OF STAGES	2

#### Cooling settings



##### Material losses

Condensation caused by the temperature falling below the dew point can lead to material losses. The appliance is therefore approved exclusively for area cooling. For dew point independent cooling, additional accessories (CDT 180) are required to ensure that any condensate is reliably drained away.

- ▶ Observe the instructions for the heat pump manager.

Adjusting the heat pump manager settings for area cooling:

- ▶ With the MENU key, call up the main menu.
- ▶ Select the menu or value and confirm with OK:

SETTINGS	Value
<input type="checkbox"/> <input checked="" type="checkbox"/> COOLING	
<input type="checkbox"/> <input checked="" type="checkbox"/> COOLING	ON
<input type="checkbox"/> <input checked="" type="checkbox"/> STANDARD SETTING	
<input type="checkbox"/> <input type="checkbox"/> <input checked="" type="checkbox"/> COOLING CAPACITY	system specific
<input type="checkbox"/> <input checked="" type="checkbox"/> ACTIVE COOLING	
<input type="checkbox"/> <input type="checkbox"/> <input checked="" type="checkbox"/> AREA COOLING	ON
<input type="checkbox"/> <input type="checkbox"/> <input type="checkbox"/> <input checked="" type="checkbox"/> SET FLOW TEMPERATURE	system specific
<input type="checkbox"/> <input type="checkbox"/> <input type="checkbox"/> <input checked="" type="checkbox"/> FLOW TEMP HYSTERESIS	system specific
<input type="checkbox"/> <input type="checkbox"/> <input type="checkbox"/> <input checked="" type="checkbox"/> SET ROOM TEMPERATURE	system specific

# INSTALLATION

## Commissioning

### 13.3 Wilo-Para .../Sc circulation pumps

► Select the appropriate pump control mode for the heating system.

#### LED indicators

	Operation indicator: LED illuminates green in normal operation LED illuminates/flashes when there is a fault
	Display of selected control mode $\Delta p$ -v, $\Delta p$ -c and constant speed
	Display of selected curve (I, II, III) within the control mode
	Combinations of LED displays for venting function, manual re-start and key lock

#### Operating button

	<b>Press</b> To select control mode To select curve (I, II, III) within the control mode
	<b>Press and hold</b> To activate venting function (press for 3 seconds) For manual restart (press for 5 seconds) To lock/unlock buttons (press for 8 seconds)

#### Control modes and functions

**Variable differential pressure  $\Delta p$ -v (I, II, III)** Recommended for two-pipe heating systems with radiators to reduce flow noise at thermostatic valves

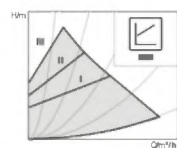

The pump reduces the delivery head by a half when the flow rate drops in pipework. Saves energy by matching the delivery head to the flow rate demand and the lower flow velocities. Choice of three pre-defined curves (I, II, III).

**Constant pressure differential  $\Delta p$ -c (I, II, III)**

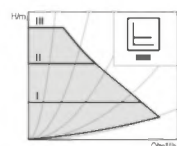

Recommended for underfloor heating systems or with large-diameter pipework and for all applications with a non-varying pipework curve (e.g. cylinder charging pumps) and single-pipe heating systems with radiators

The control system keeps the set delivery head constant, irrespective of delivered flow rate. Choice of three pre-defined curves (I, II, III).

**Constant speed (I, II, III)**

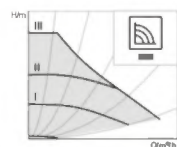

Recommended for systems with unchanging system resistance which require a constant throughput. The pump runs at three preset fixed speed levels (I, II, III).

**Note**  
Factory setting: Constant speed, curve III

#### Venting



Fill the system properly and ventilate it  
If the pump is not ventilated automatically:  
Activate venting function via the operating button:  
Press for 3 seconds then release.  
Venting function starts (duration 10 minutes).  
The top and bottom rows of LEDs flash alternately every second.

To cancel, press the operating button for 3 seconds.

**Note**  
After venting, the LED indicator displays the previously set pump values.

#### Setting control modes

##### Selecting the control mode



The LEDs for the control modes and associated curves illuminate one after the other.

Briefly press the operating button (for approx. 1 second).  
LEDs indicate the current selected control mode and curve (see following table).

Operating button	LED indicator	Control mode	Curve
1x		Constant speed	II
2x		Constant speed	I
3x		Variable differential pressure $\Delta p$ -v	III
4x		Variable differential pressure $\Delta p$ -v	II
5x		Variable differential pressure $\Delta p$ -v	I
6x		Constant differential pressure $\Delta p$ -c	III
7x		Constant differential pressure $\Delta p$ -c	II
8x		Constant differential pressure $\Delta p$ -c	I
*9x		Constant speed	III

(\* ) Pressing the button for the 9th time in succession returns the system to the factory setting (constant speed, curve III).

## INSTALLATION

# Shutting down the system

### 13.4 Appliance handover

- ▶ Explain the appliance function to users and familiarise them with how it works.
- ▶ Make users aware of potential dangers.
- ▶ Hand over these instructions.

## 14. Shutting down the system



#### Material losses

Observe the temperature application limits and the minimum circulation volume on the heat consumer side (see chapter "Specification / Data table").



#### Material losses

Drain the system when there is a risk of frost and the heat pump is completely switched off (see chapter "Maintenance / Draining the DHW cylinder").

- ▶ If you take the system out of use, set the heat pump manager to standby so that the safety functions that protect the appliance (e.g. frost protection) remain active.

## 15. Maintenance



#### WARNING Electrocutation

Carry out all electrical connection and installation work in accordance with relevant regulations.



#### WARNING Electrocutation

▶ Before any work on the appliance, disconnect all poles of the appliance from the power supply.

### Draining the buffer cylinder

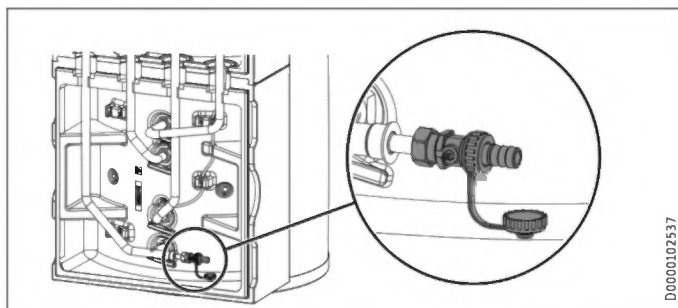

- ▶ Drain the buffer cylinder via the lower drain & fill valve.

### Draining the DHW cylinder



#### CAUTION Burns

Hot water may escape during draining.

- ▶ Close the shut-off valve in the cold water supply line.
- ▶ Open the hot water taps on all draw-off points.

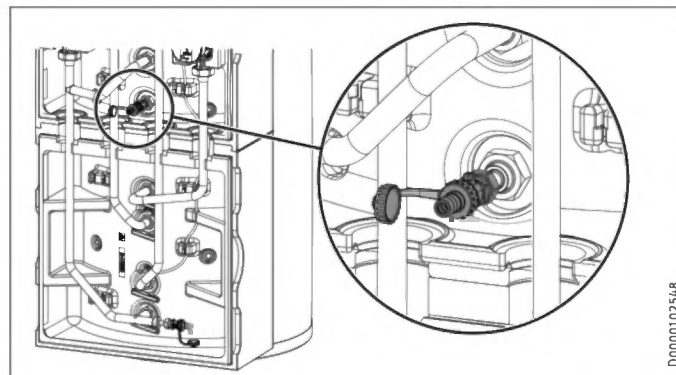

- ▶ Drain the DHW cylinder via the upper drain & fill valve.

### Testing the sacrificial anode

- ▶ Arrange for the sacrificial anode to be tested at least every two years and replace immediately if it becomes depleted. For this, observe the maximum transition resistance between the sacrificial anode and the cylinder of 0.3  $\Omega$ . If it is not possible to insert the sacrificial anode from above, install a segmented anode.

The intervals at which subsequent testing should be carried out depends on the wear of the sacrificial anode.

## 16. Specification

### 16.1 Dimensions and connections

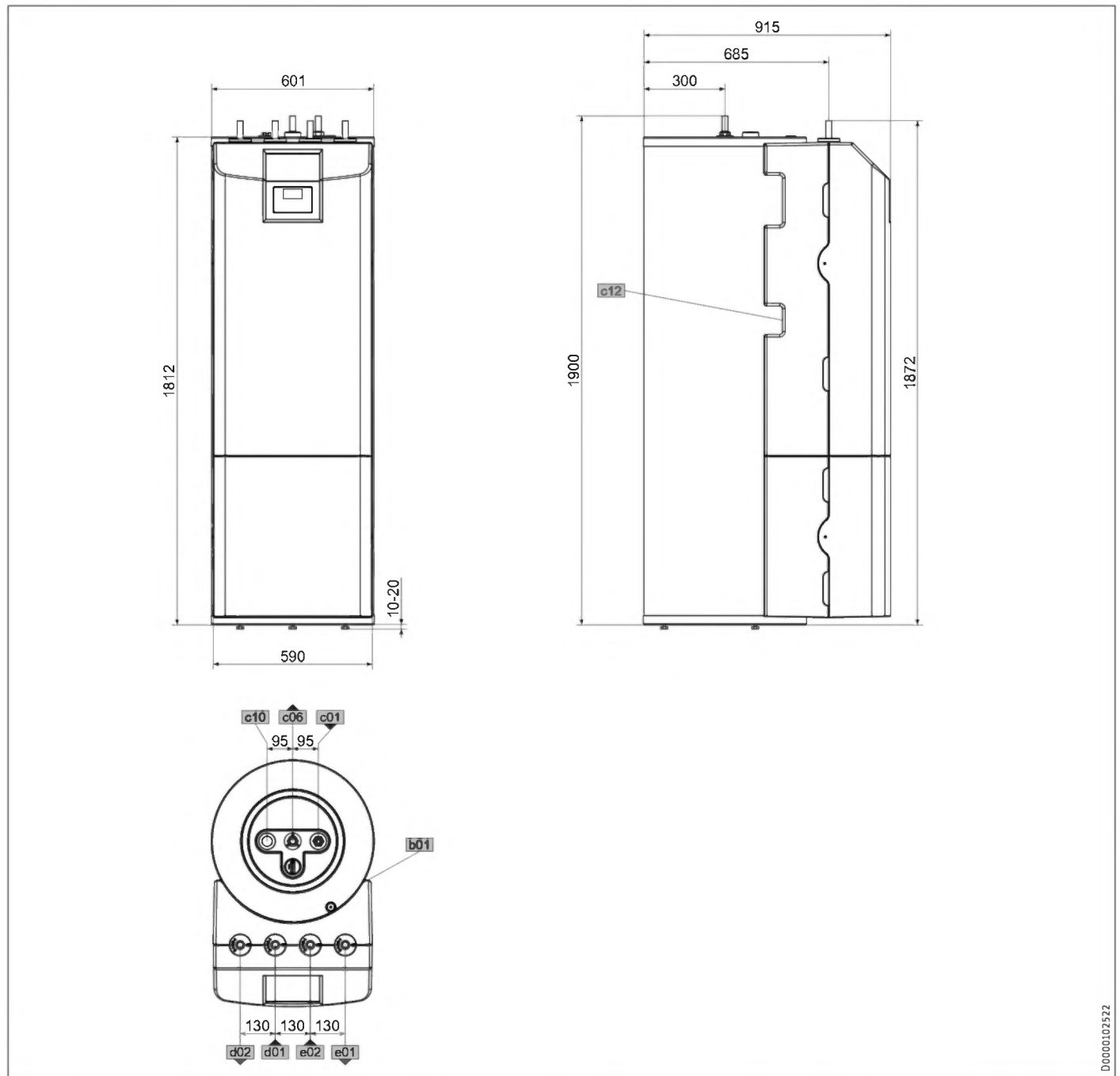

			HSBC 180 Plus	HSBC 180 S Plus
b01	Entry electrical cables			
c01	Cold water inlet	Diameter	mm 22	22
c06	DHW outlet	Diameter	mm 22	22
c10	DHW circulation	Diameter	mm 15	15
c12	Safety assembly drain	Diameter	mm 23	23
d01	Heat pump flow	Diameter	mm 22	22
d02	Heat pump return	Diameter	mm 22	22
e01	Heating flow	Diameter	mm 22	22
e02	Heating return	Diameter	mm 22	22

# INSTALLATION

## Specification

### Other dimensions and connections

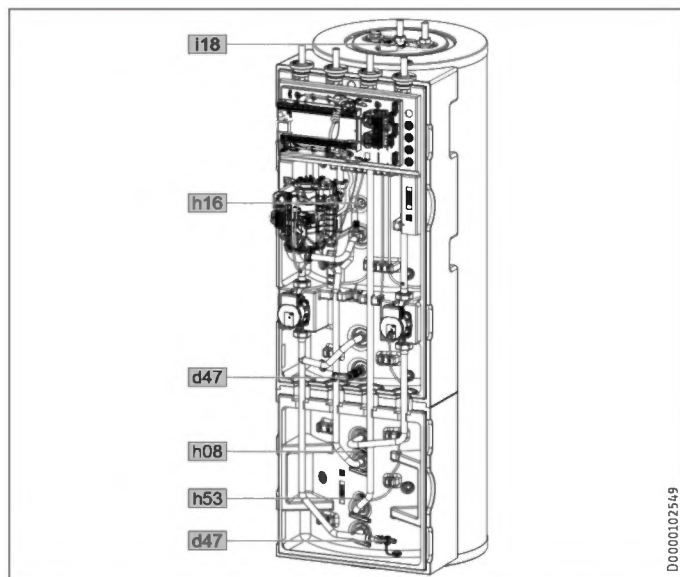

				HSBC 180 plus	HSBC 180 S Plus
h08	Sensor heat pump cooling	Diameter	mm	9,5	9,5
h16	Sensor DHW	Diameter	mm	9,5	9,5
h53	Sensor heating	Diameter	mm	9,5	9,5
i18	Sacrificial anode	Female thread		G 1 1/4	G 1 1/4
		Torque	Nm	120	120
d47	Drain & fill valve				

# INSTALLATION Specification

## 16.2 Wiring diagram

### HSBC 180 plus

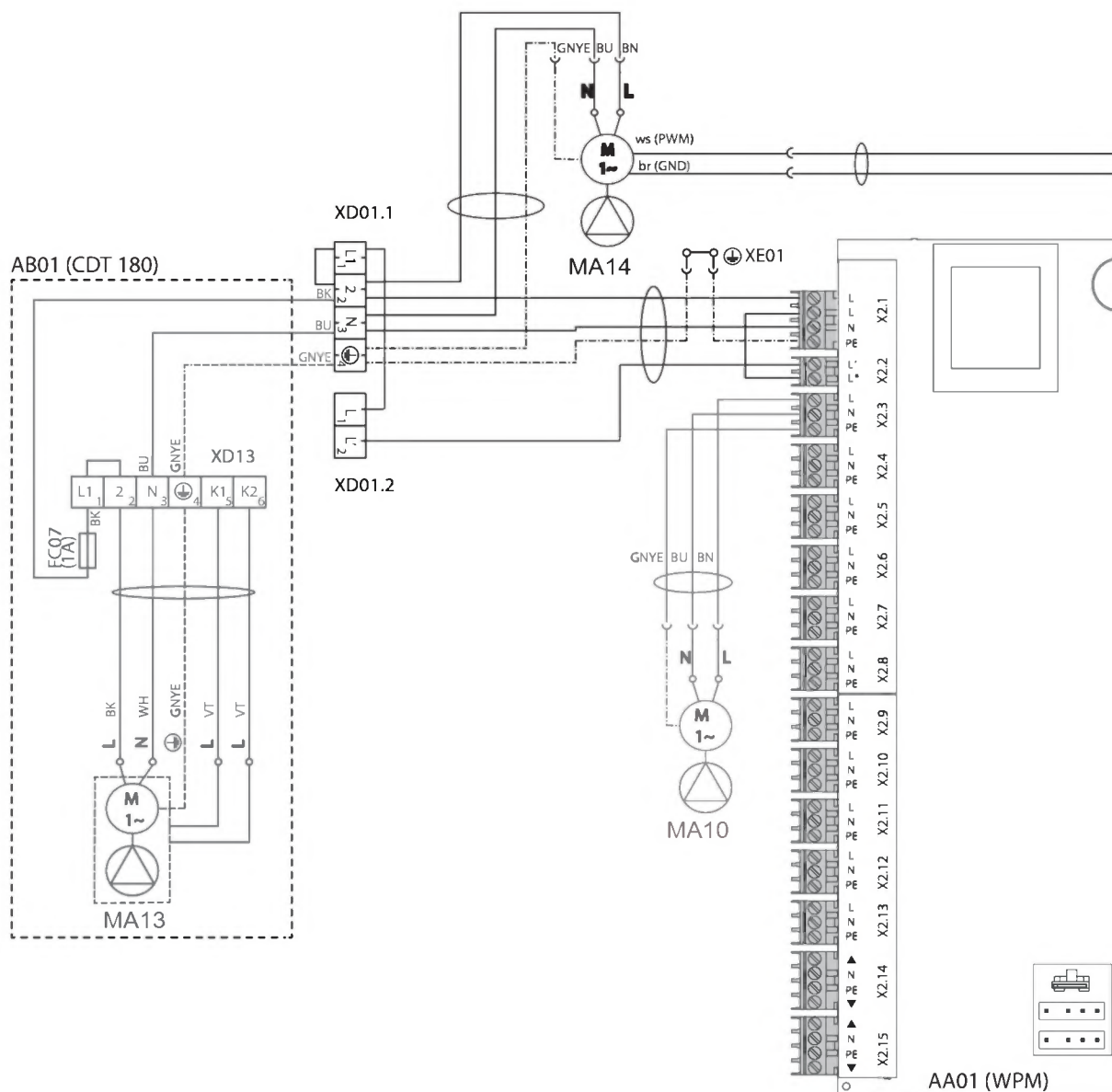

AA01	Extra low voltage (WPM 4 heat pump manager)
AA06	Programming unit
AA07	PCB, booster heater MFG
EB01	Booster heater MFG
BF01	Flow rate and temperature, heating circuit
BP10	Heating circuit pressure sensor
BT01	Temperature sensor, heat pump flow
BT02	Temperature sensor, heat pump return
BT06	Temperature sensor, heat pump buffer cylinder
BT08	Temperature sensor, HP cooling
BT20	Temperature sensor, DHW cylinder
BT55	High limit safety cut-out MFG (manual reset)
FC07	Condensate pump fuse
MA10	Motor, pump, heating circuit
MA13	Condensate pump motor
MA14	Motor, buffer charging pump (PWM/1-10V)

MA15	Motor, diverter valve, heating/DHW
KF20	Relay, booster heater MFG
KF21	Relay, booster heater MFG
KF22	Relay, booster heater MFG
XD01.1	Terminal, power supply
XD01.2	Terminal, power-OFF contact
XD02	Terminal, MFG power supply
XD13	Terminal, condensate pump
XE01	Power supply earth terminal
XE02	Earth terminal MFG/DHC
XE05	Earth stud, front panel
XE06	Earth, front panel
AA01-X1.1	Connector, CAN A (heat pump connection)
AA01-X1.2	Connector, CAN B (FET/ISG connection)
AA01-X1.3	Connector, outside temperature sensor
AA01-X1.4	Connector, buffer temperature sensor BT06

# INSTALLATION Specification

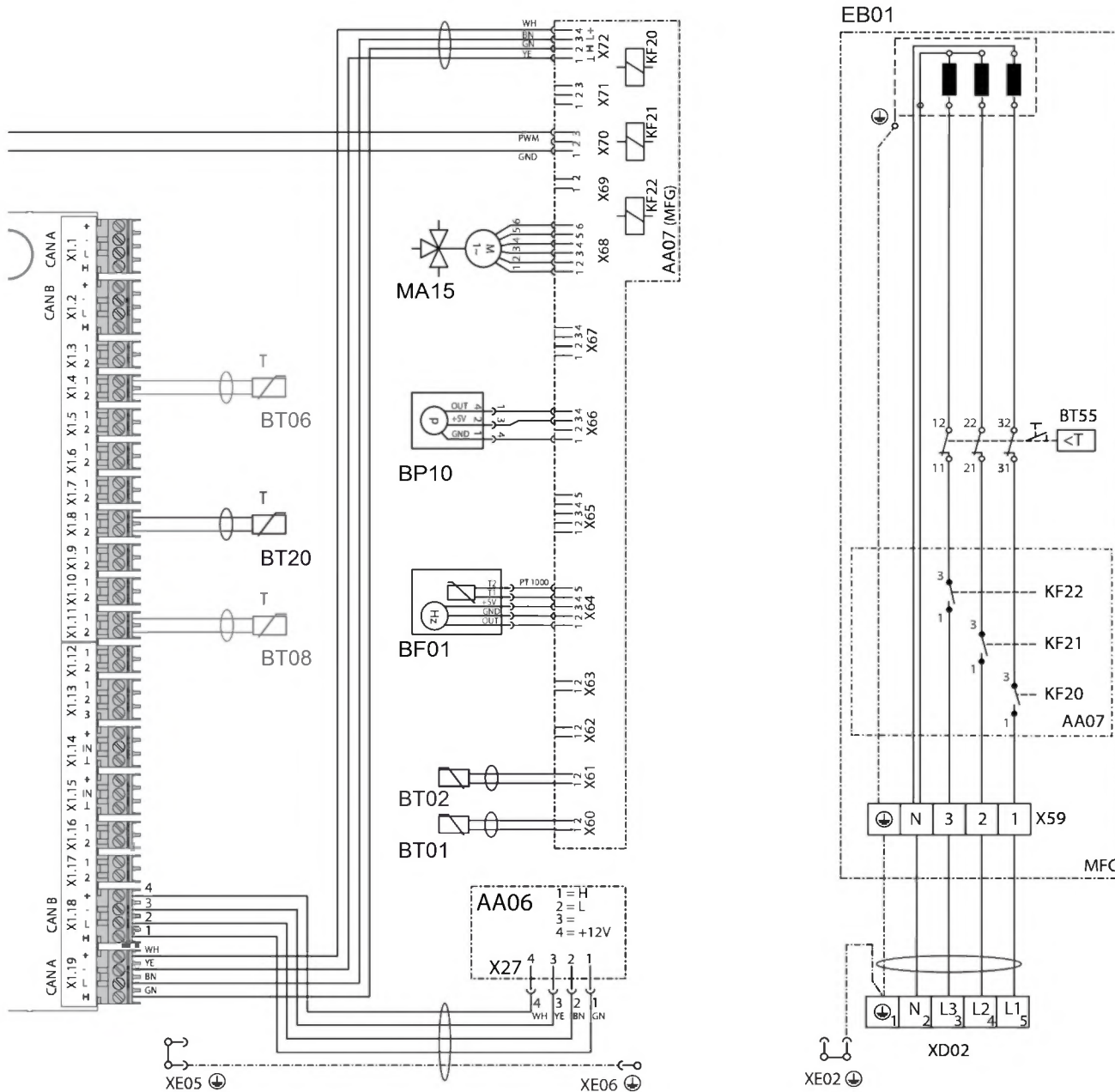

AA01-X1.5	Connector, flow temperature sensor	AA07-X61	Connector, temperature sensor, heat pump return BT02
AA01-X1.6	Connector, heating circuit temperature sensor 2	AA07-X62	Not assigned – connector, temperature sensor, heat pump return
AA01-X1.7	Connector, heating circuit temperature sensor 3	AA07-X63	Not assigned – connector, temperature sensor, DHW cylinder, internal
AA01-X1.8	Connector, DHW cylinder sensor BT20	AA07-X64	Connector, temperature and flow rate, heating circuit, BF01
AA01-X1.9	Connector, source sensor	AA07-X65	Not assigned
AA01-X1.10	Connector, 2nd heat generator	AA07-X66	Rast 2.5 connector (heating system pressure) BP01
AA01-X1.11	Connector, flow, cooling	AA07-X67	Not assigned
AA01-X1.12	Connector, DHW circulation sensor	AA07-X68	Connector, switching, motor, diverter valve central heating / DHW
AA01-X1.13	Connector, remote control FE7	AA07-X69	Not assigned
AA01-X1.14	Connector, analogue input 0-10 V	AA07-X70	Connector, switching, pump, heating circuit PWM/1-10V
AA01-X2.14	Connector, mixer, heating circuit 2 (X2.14.1 Mixer OPEN/X2.14.2 Mixer CLOSE)	AA07-X71	Not assigned
AA01-X2.15	Connector, mixer, heating circuit 3 (X2.15.1 Mixer OPEN/X2.15.2 Mixer CLOSE)	AA07-X72	Connector, CAN bus
AA06-X27	Terminal, programming unit	EB01-X59	Terminal, MFG
AA07-X60	Connector, temperature sensor, heat pump flow BT01		

# INSTALLATION Specification

## HSBC 180 S Plus

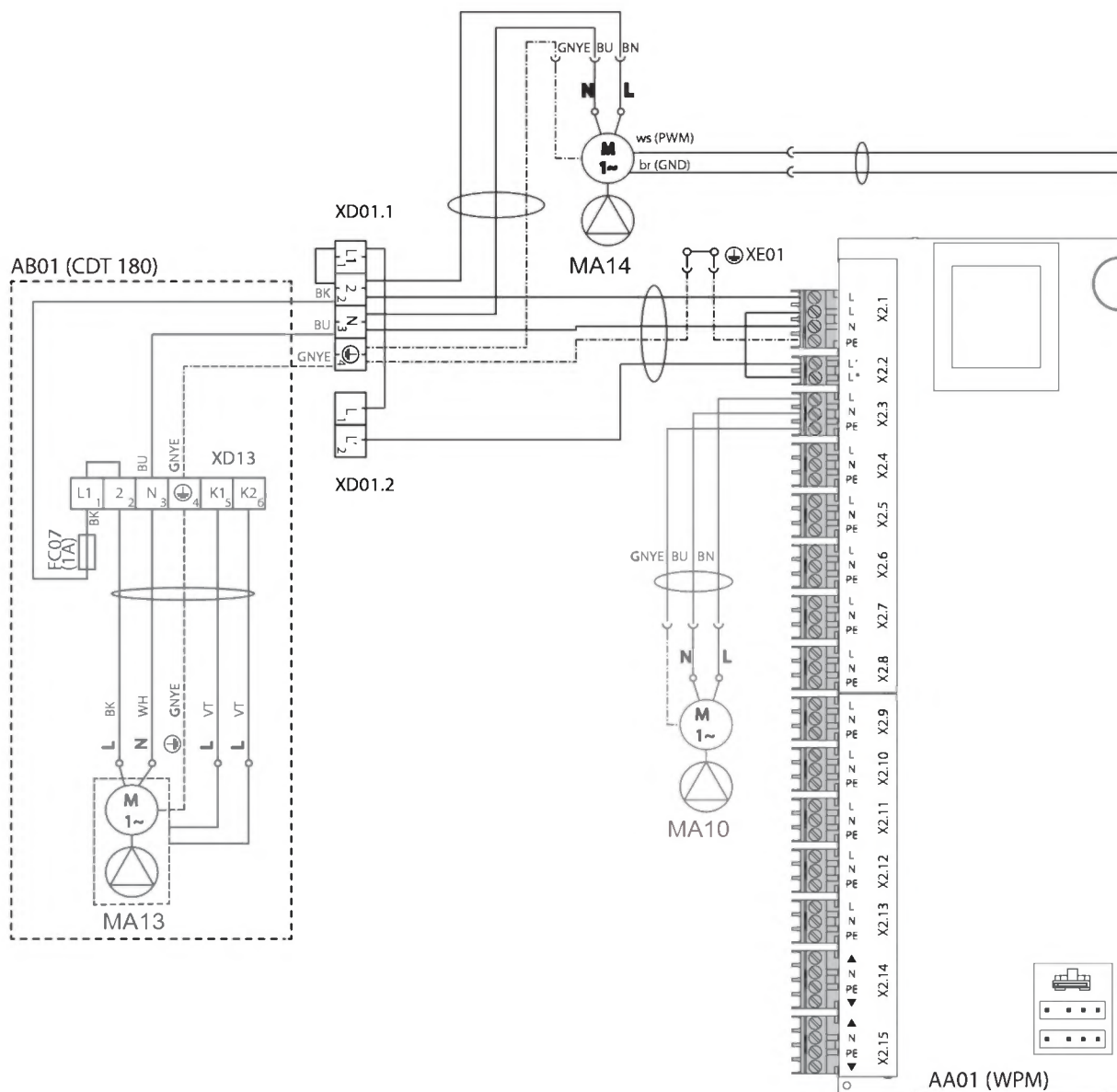

AA01	Extra low voltage (WPM 4 heat pump manager)
AA06	Programming unit
AA07	PCB, booster heater MFG
EB01	Booster heater MFG
BF01	Flow rate and temperature, heating circuit
BP10	Heating circuit pressure sensor
BT01	Temperature sensor, heat pump flow
BT02	Temperature sensor, heat pump return
BT06	Temperature sensor, heat pump buffer cylinder
BT08	Temperature sensor, HP cooling
BT20	Temperature sensor, DHW cylinder
BT55	High limit safety cut-out MFG (manual reset)
FC07	Condensate pump fuse
MA10	Motor, pump, heating circuit
MA13	Condensate pump motor
MA14	Motor, buffer charging pump (PWM/1-10V)
MA15	Motor, diverter valve, heating/DHW
KF20	Relay, booster heater MFG

KF21	Relay, booster heater MFG
KF22	Relay, booster heater MFG
XD01.1	Terminal, power supply
XD01.2	Terminal, power-OFF terminal
XD02	Terminal, MFG power supply
XD13	Terminal, condensate pump
XE01	Power supply earth terminal
XE02	Earth terminal MFG/DHC
XE05	Earth stud, front panel
XE06	Earth, front panel
AA01-X1.1	Connector, CAN A (heat pump connection)
AA01-X1.2	Connector, CAN B (FET/ISG connection)
AA01-X1.3	Connector, outside temperature sensor
AA01-X1.4	Connector, buffer temperature sensor BT06
AA01-X1.5	Connector, flow temperature sensor
AA01-X1.6	Connector, heating circuit temperature sensor 2
AA01-X1.7	Connector, heating circuit temperature sensor 3
AA01-X1.8	Connector, DHW cylinder sensor BT20

# INSTALLATION Specification

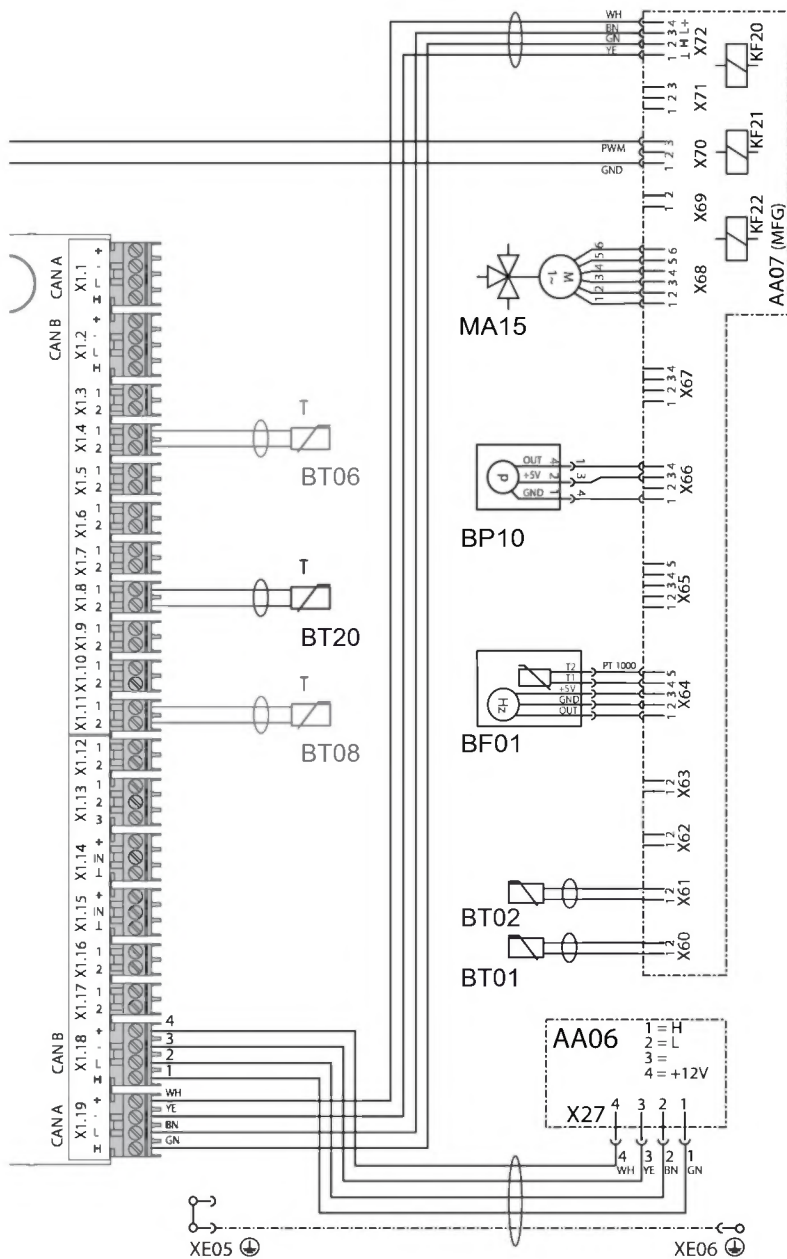

AA01-X1.9	Connector, source sensor	AA07-X66	Rast 2.5 connector (heating system pressure) BP01
AA01-X1.10	Connector, 2nd heat generator	AA07-X67	Not assigned
AA01-X1.11	Connector, flow, cooling	AA07-X68	Connector, switching, motor, diverter valve central heating / DHW
AA01-X1.12	Connector, DHW circulation sensor	AA07-X69	Not assigned
AA01-X1.13	Connector, remote control FE7	AA07-X70	Connector, switching, pump, heating circuit PWM/1-10V
AA01-X1.14	Connector, analogue input 0-10 V	AA07-X71	Not assigned
AA01-X2.14	Connector, mixer, heating circuit 2 (X2.14.1 Mixer OPEN/X2.14.2 Mixer CLOSE)	AA07-X72	Connector, CAN bus
AA01-X2.15	Connector, mixer, heating circuit 3 (X2.15.1 Mixer OPEN/X2.15.2 Mixer CLOSE)	EB01-X59	Terminal, MFG
AA06-X27	Terminal, programming unit		
AA07-X60	Connector, temperature sensor, heat pump flow BT01		
AA07-X61	Connector, temperature sensor, heat pump return BT02		
AA07-X62	Not assigned - connector, temperature sensor, heat pump return		
AA07-X63	Not assigned - connector, temperature sensor, DHW cylinder, internal		
AA07-X64	Connector, temperature and flow rate, heating circuit, BF01		
AA07-X65	Not assigned		

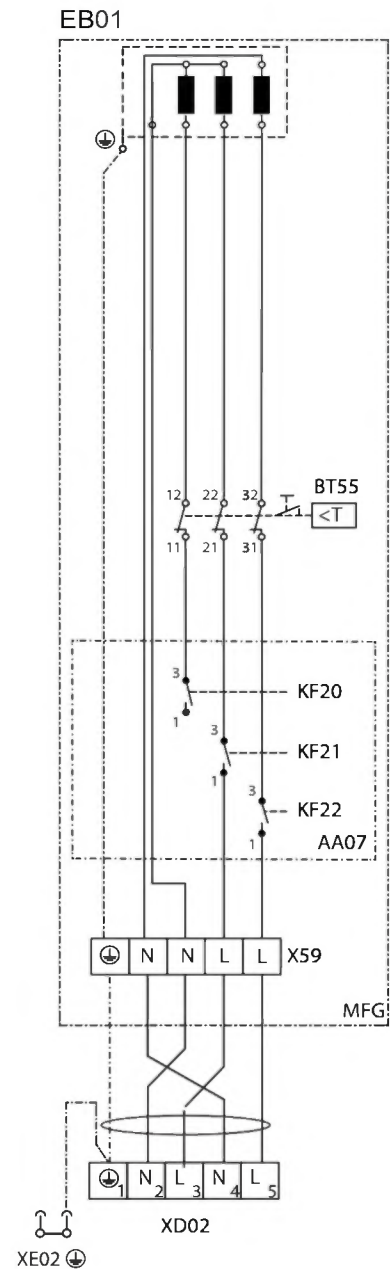

# INSTALLATION Specification

## 16.3 Energy consumption data

Product datasheet: DHW cylinder to Regulation (EU) No 812/2013 (S.I. 2019 No. 539 / Programme 2)

		HSBC 180 plus	HSBC 180 S Plus
		202927	203082
Manufacturer		STIEBEL ELTRON	STIEBEL ELTRON
Supplier's model identifier		HSBC 180 plus	HSBC 180 S Plus
Energy efficiency class		B	B
Standby losses S	W	53.9	53.9
Cylinder capacity V	l	195	195

## 16.4 Data table

		HSBC 180 Plus	HSBC 180 S Plus
		202927	203082
<b>Hydraulic data</b>			
Nominal capacity, DHW cylinder	l	178	178
Nominal capacity, buffer cylinder	l	80	80
Surface, indirect coil	m <sup>2</sup>	1.59	1.59
Content, indirect coil	l	10	10
External available pressure differential, circulation pump / heat pump at 1.0 m <sup>3</sup> /h	hPa	690	690
External available pressure differential, circulation pump / heat pump at 1.5 m <sup>3</sup> /h	hPa	461	461
External available pressure differential, circulation pump / heat pump at 2.0 m <sup>3</sup> /h	hPa	219	219
External available pressure differential, circulation pump / heating circuit 1 at 1.0 m <sup>3</sup> /h	hPa	728	728
External available pressure differential, circulation pump / heating circuit 1 at 1.5 m <sup>3</sup> /h	hPa	555	555
External available pressure differential, circulation pump / heating circuit 1 at 2.0 m <sup>3</sup> /h	hPa	401	401
<b>Application limits</b>			
Max. permissible pressure, DHW cylinder	MPa	1.00	1.00
Test pressure, DHW cylinder	MPa	1.50	1.50
Max. throughput	l/min	25	25
Max. permissible pressure, buffer cylinder	MPa	0.30	0.30
Test pressure, buffer cylinder	MPa	0.45	0.45
Max. permissible temperature	°C	95	95
Max. permissible temperature, primary side	°C	75	75
<b>Heating water quality requirements</b>			
Water hardness	°dH	≤3	≤3
pH value (with aluminium compounds)		8.0-8.5	8.0-8.5
pH value (without aluminium compounds)		8.0-10.0	8.0-10.0
Conductivity (softening)	µS/cm	< 1000	< 1000
Conductivity (desalinating)	µS/cm	20-100	20-100
Chloride	mg/l	< 30	< 30
Oxygen 8-12 weeks after filling (softening)	mg/l	<0.02	<0.02
Oxygen 8-12 weeks after filling (desalinating)	mg/l	< 0.1	< 0.1
<b>Power consumption</b>			
Power consumption, emergency/booster heater	kW	8.80	5.90
Max. power consumption, charging pump	W	60	60
Max. power consumption, circulation pump, heating side	W	60	60
<b>Energy data</b>			
Standby energy consumption/24 h at 65 °C	kWh	1.29	1.29
Energy efficiency class		B	B
<b>Electrical details</b>			
Rated control voltage	V	230	230
Control phases		1/N/PE	1/N/PE
Control circuit fuse	A	1 x B 16	1 x B 16
Rated voltage, emergency/booster heater	V	400	230
Phases, emergency/booster heater		3/N/PE	2/N/PE
Emergency/booster heater fuse	A	3 x B 16	2 x B 16
Frequency	Hz	50	50
<b>Versions</b>			
IP-Rating		IP20	IP20

# INSTALLATION | GUARANTEE | ENVIRONMENT AND RECYCLING

## Specification

		HSBC 180 Plus	HSBC 180 S Plus
<b>Dimensions</b>			
Height	mm	1910	1910
Width	mm	605	605
Depth	mm	917	917
Height of unit when tilted	mm	2007	2007
<b>Weights</b>			
Weight (wet)	kg	407	407
Weight (dry)	kg	134	134

### Further details

		HSBC 180 plus	HSBC 180 S Plus
		202927	203082
Maximum height for installation	m	2000	2000

## Guarantee

The guarantee conditions of our German companies do not apply to appliances acquired outside of Germany. In countries where our subsidiaries sell our products a guarantee can only be issued by those subsidiaries. Such guarantee is only granted if the subsidiary has issued its own terms of guarantee. No other guarantee will be granted.

We shall not provide any guarantee for appliances acquired in countries where we have no subsidiary to sell our products. This will not affect warranties issued by any importers.

## Environment and recycling

We would ask you to help protect the environment. After use, dispose of the various materials in accordance with national regulations.