

OPERATION AND INSTALLATION

Central ventilation appliance with heat recovery

- » LWZ 170 E plus
- » LWZ 370 plus

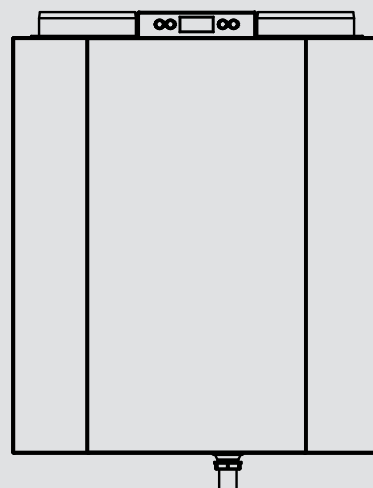

STIEBEL ELTRON

SPECIAL INFORMATION

OPERATION

1. General information	3
1.1 Safety instructions	3
1.2 Other symbols in this documentation	3
1.3 Standardised output data	3
1.4 Units of measurement	3
2. Safety	3
2.1 Intended use	3
2.2 General safety instructions	4
2.3 Test symbols	4
3. Appliance description	4
4. Settings	5
4.1 Remote control	5
4.2 User interface on the appliance	5
4.3 Switching the appliance on	5
4.4 Switching off the appliance	6
4.5 Standard mode	6
5. Maintenance, cleaning and care	7
5.1 Replacement filter	7
5.2 Cleaning filters	7
6. Troubleshooting	9
6.1 Fault analysis	9
6.2 Fault codes	9

INSTALLATION

7. Safety	10
7.1 General safety instructions	10
7.2 Instructions, standards and regulations	10
7.3 Operation of the appliance in buildings with combustion equipment	10
7.4 Operating the appliance in passive houses	11
8. Appliance description	11
8.1 Standard delivery	11
8.2 Required accessories	11
8.3 Further accessories	11
9. Preparations	11
9.1 Installation site	11
9.2 Transport	11
10. Installation	11
10.1 Mounting the appliance	11
10.2 Connecting the condensate drain	12
10.3 Connecting air ducts	12
10.4 Power supply	13
11. Commissioning	17
11.1 Initial start-up	17
11.2 Shutdown	17
11.3 Recommissioning	17
12. Settings	17
12.1 Settings menu	17
12.2 Read-out menu	21
12.3 Service menu	21

12.4 Restoring factory settings	22
13. Maintenance	23
14. Troubleshooting	25
15. Disposal	26
16. Specification	26
16.1 Dimensions and connections	26
16.2 Minimum clearances	27
16.3 Data table	27
16.4 Wiring diagram	28
16.5 Sound	28
16.6 Fan diagram	29

GUARANTEE

ENVIRONMENT AND RECYCLING

SPECIAL INFORMATION

- The appliance may be used by children aged 8 and up and persons with reduced physical, sensory or mental capabilities or a lack of experience and know-how, provided that they are supervised or they have been instructed on how to use the appliance safely and have understood the resulting risks. Children must never play with the appliance. Children must never clean the appliance or perform user maintenance unless they are supervised.
- The power cable must only be replaced (for example if damaged) by qualified contractors authorised by the manufacturer.
- Secure the appliance as described in chapter "Installation / Installation".

OPERATION

1. General information

The chapters “Special Information” and “Operation” are intended for appliance users and qualified contractors.

The chapter "Installation" is intended for qualified contractors.



Note
Read these instructions carefully before using the appliance and retain them for future reference. Pass on the instructions to any new user where appropriate.

1.1 Safety instructions

1.1.1 Structure of safety instructions



KEYWORD Type of risk
Here, possible consequences are listed that may result from failure to observe the safety instructions.
► Steps to prevent the risk are listed.

1.1.2 Symbols, type of risk

Symbol	Type of risk
	Injury
	Electrocution
	Burns (burns, scalding)

1.1.3 Keywords

KEYWORD	Meaning
DANGER	Failure to observe this information will result in serious injury or death.
WARNING	Failure to observe this information may result in serious injury or death.
CAUTION	Failure to observe this information may result in non-serious or minor injury.

1.2 Other symbols in this documentation



Note
General information is identified by the adjacent symbol.
► Read these texts carefully.

Symbol	Meaning
	Material losses (appliance damage, consequential losses and environmental pollution)

Symbol	Meaning
	Appliance disposal

► This symbol indicates that you have to do something. The action you need to take is described step by step.

1.3 Standardised output data

Explanations to determine and interpret the specified standardised output data

1.3.1 Standard: EN 13141-7

The output data specifically mentioned in text, diagrams and technical datasheets has been determined in line with the test conditions described in the standard shown in the heading of this chapter.

Generally, these standardised test conditions will not fully meet the conditions found at the installation site of the system user. Depending on the chosen test method and the extent to which the selected method deviates from the conditions described in the standard shown in the heading of this chapter, any deviations can have a considerable impact. Further factors that have an influence on the test values are the measuring equipment, the system configuration, the age of the system and the flow rates.

A confirmation of the specified output data can only be obtained if the conditions applicable to the relevant test match those of the standard shown in the heading of this chapter.

1.4 Units of measurement



Note
All measurements are given in mm unless stated otherwise.

2. Safety

2.1 Intended use

The appliance is designed as a mechanical ventilation unit with centralised supply air and extract air routing.

This appliance is intended for domestic use. It can be used safely by untrained persons. The appliance can also be used in a non-domestic environment, e.g. in a small business, as long as it is used in the same way.

Any other use beyond that described shall be deemed inappropriate. Observation of these instructions and of instructions for any accessories used is also part of the correct use of this appliance.

Appliance description

It is deemed inappropriate to:

- Use extract air loaded with grease, explosive gases, dust or adhesive aerosols
- Install the unit outdoors
- Connect cooker hoods and dryer exhausts to the ventilation system.

Never adjust the setting of supply and extract air valves inside the rooms. These have been set up by a qualified contractor during commissioning.

2.2 General safety instructions

 **WARNING Injury**
 The appliance may be used by children aged 8 and up and persons with reduced physical, sensory or mental capabilities or a lack of experience and know-how, provided that they are supervised or they have been instructed on how to use the appliance safely and have understood the resulting risks. Children must never play with the appliance. Children must never clean the appliance or perform user maintenance unless they are supervised.

 **Note**
 Trouble-free operation of the appliance is only possible with a closed appliance cover.

2.3 Test symbols

See type plate on the appliance.

3. Appliance description

The appliance draws in outdoor air with a fan. A second fan draws in extract air from rooms in the home with odour or humidity loads (kitchen, bathroom and WC). Extract air and outdoor air are routed through separate ducts. Extract air and outdoor air are filtered by separate filters.





Both air streams are routed through a cross-countercurrent heat exchanger. The extract air gives off heat, which is transferred to the outdoor air. This means that the extracted stale indoor air heats the fresh clean outdoor air, saving energy and routing fresh air into the interior.

The appliance has a filter service indicator, as well as an optional filter service indicator at the stage switch.

The appliance has a frost protection control unit, which ensures that the appliance works to optimum effect even at low outside temperatures. If required, the frost protection control unit switches on the integral preheater coil.

The appliance is fully wired when delivered and works fully automatically.

The air flow rate is preset for each fan stage by the qualified contractor. Constant flow rate control ensures that the air flow rates of the supply air and extract air are achieved irrespective of the duct pressure.

Fan stage	
	Humidity protection ventilation: This fan stage prevents mould formation using the factory-set air flow rate of 50 m ³ /h. Alternatively, the contractor can set an air flow rate of 0 m ³ /h when commissioning the appliance. In such a case, no humidity protection is provided.
	Fan stage 1 should be seen as background ventilation, to be selected when going away for example.
	Fan stage 2 is recommended for standard ventilation.
	Fan stage 3 is recommended as intensive ventilation, to temporarily increase the air flow rate for load peaks (e.g. as a party stage).

Bypass function

An automatic bypass damper is built into the appliance. The bypass damper enables the supply of fresh air, which is not heated by the heat exchanger. Cool, fresh air is required on summer nights in particular. In such cases, as much of the warm air in the home as possible is displaced by cooler fresh air.

The bypass damper opens and closes automatically when the following conditions are met.

Bypass damper position	Conditions
Open	The outside temperature is higher than 10 °C and lower than the room temperature, and the room temperature is higher than the bypass temperature set in parameter 05.
Sealed unvented	The outside temperature is lower than 10 °C. The outside temperature is at least 0.5 °C higher than the room temperature. The room temperature is lower than the bypass temperature reduced by the bypass hysteresis. The bypass temperature is set in parameter 05. The bypass hysteresis is set in parameter 06.

When the bypass damper is opened, the extract air does not flow through the cross-countercurrent heat exchanger, but is instead routed directly as exhaust air out of the building. This means there is no transfer of heat to the supply air.

Frost protection

The appliance has a frost protection control unit and an integral preheater coil to prevent the cross-countercurrent heat exchanger from freezing up.

Once the frost protection control unit has been enabled (-1.5 °C), the preheater coil is only switched on when the heat exchanger begins to ice up, at an output that is infinitely variable. The frost protection control unit detects icing-up of the heat exchanger when the pressure increases on the extract air side of the appliance. The supply and extract air fans continue to run with the same air flow rates.

Only when the output of the preheater coil becomes insufficient for de-icing does the control unit reduce the speed of the supply air fan variably until it stops.

OPERATION

Settings

4. Settings



Note

User operations at the appliance are restricted to switching the appliance ON and OFF.

4.1 Remote control

Observe the operating and installation instructions for the relevant remote control (see chapter "Appliance description / Required accessories" or "Appliance description / Other accessories").

4.2 User interface on the appliance

The appliance has a user interface with display. This enables air flow rates to be variably adjusted or operating details to be checked.

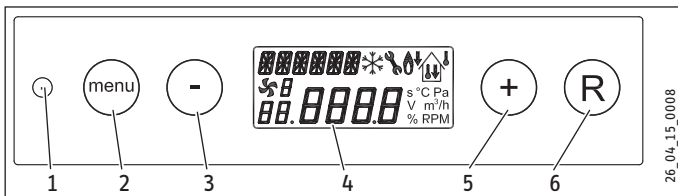

- 1 Service plug-in connection
- 2 Menu key
- 3 Minus key
- 4 LCD
- 5 Plus key
- 6 R key

With the four control keys (menu, plus, minus, R), you can call up and change settings.

When the mains power is switched on, all available symbols are displayed for two seconds. In addition, the backlighting is activated for 60 seconds. If one of the control keys is pressed, the display is illuminated for 30 seconds.

If no keys are pressed and/or if no blocking fault occurs, standard mode is displayed.

When the menu key is pressed, you can use the plus or minus key to choose between three different sub-menus:

- Settings menu (SET)
- Read-out menu (READ)
- Service menu (SERV)

With the R key, you can exit any selected menu and return to standard mode.

To switch on the display backlight without changing anything in the menu, press the R key briefly (less than 5 seconds).

Button	Key function
Menu	Open menu; open sub-menu; enable parameter for value change; confirm value change
-	Scroll; adjust value; switch appliance on or off from standard mode (press and hold down for 5 seconds)
+	Scroll; adjust value
R	One step back in the menu; reset adjusted value; filter reset (press and hold down for 5 seconds); delete fault history

4.3 Switching the appliance on

- Plug the appliance into a standard socket.

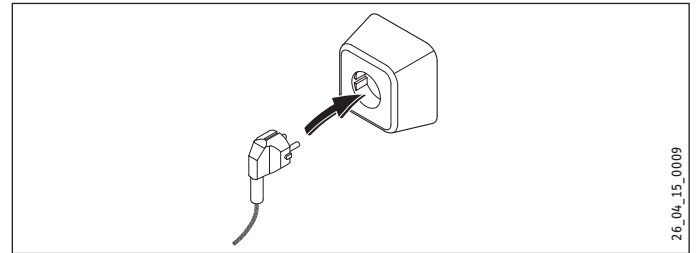

All display symbols are shown for two seconds.

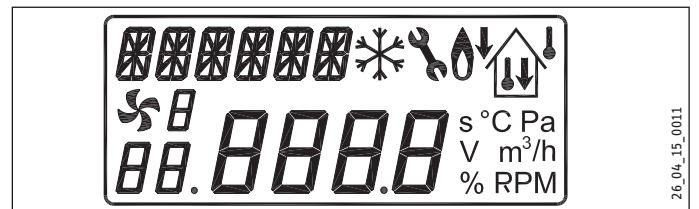

The software version is displayed for two seconds.

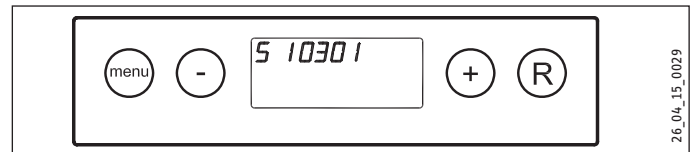

The appliance then runs according to the stage switch setting. If no stage switch is connected, the appliance always runs in fan stage 1.

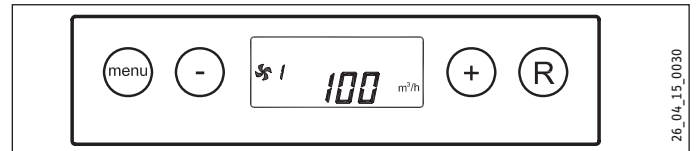

Switching on via software

If the appliance has been switched off via software, "OFF" is displayed.

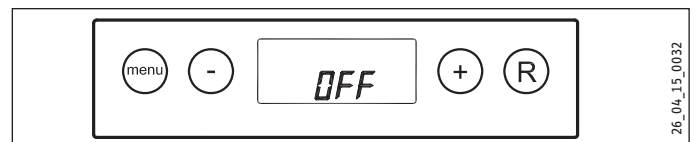

- Switch on the appliance by pressing the minus button for 5 seconds.

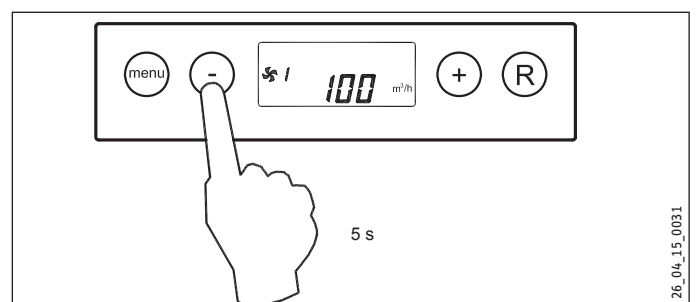

OPERATION

Settings

4.4 Switching off the appliance

Switching off via software

- ▶ Press and hold down the minus button for 5 seconds to switch off the appliance.

The display shows "OFF".

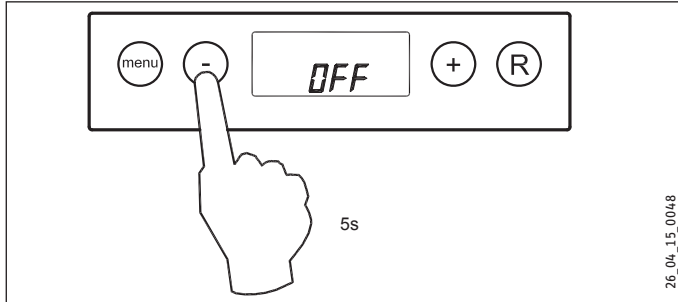

Interrupting the power supply

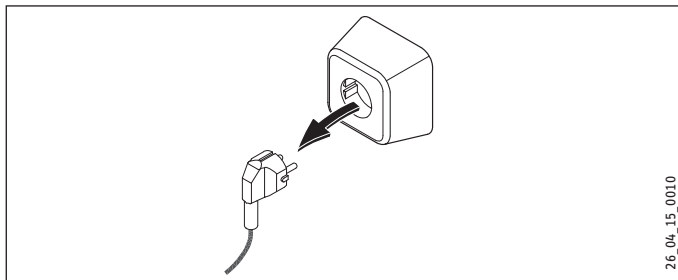

The display is now blank.



WARNING Electrocutation

Before working on the appliance, always isolate the appliance from the power supply by first switching the appliance off via the software and then unplugging it from the mains.

4.5 Standard mode

In standard mode, the display shows up to four different pieces of information (operating modes and values) simultaneously.

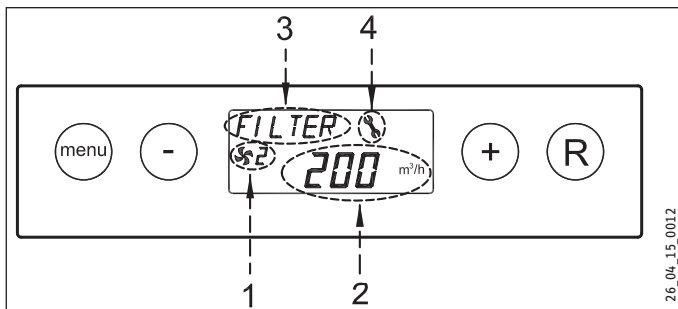

- 1 Indication of the fan stage, indication of connected appliances
- 2 Indication of the air flow rate
- 3 Message text, e.g. filter status text, triggering of external switching contact, etc.
- 4 Fault symbol

4.5.1 Fan stage

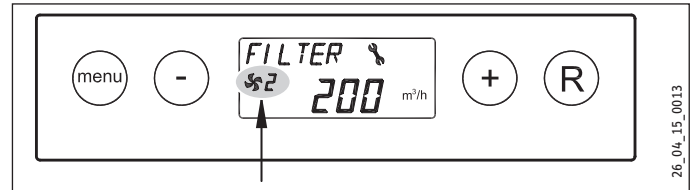

A fan symbol is displayed when the supply air fan and the extract air fan rotate. The fan symbol is not visible when the fans are at a standstill.

The number after the fan symbol indicates the fan stage.

Fan stage indicator	Description
	The supply air and extract air fans generate an air flow rate of 50 m³/h or stop. This depends on the setting of parameter 01. This fan stage cannot be enabled with a 3-stage switch.
	The supply air and extract air fans rotate according to stage 1 of the stage switch. The air flow rate depends on the parameter 02 setting.
	The supply air and extract air fans rotate according to stage 2 of the stage switch. The air flow rate depends on the parameter 03 setting.
	The supply air and extract air fans rotate according to stage 3 of the stage switch. The air flow rate depends on the parameter 04 setting.
	This appliance has been connected using an eBUS or OpenTherm coupling. The supply air and extract air fans rotate according to the fan stage selected at the master appliance. If the appliance is connected in a cascade, the slave number of the appliance is displayed.

4.5.2 Indication of the air flow rate

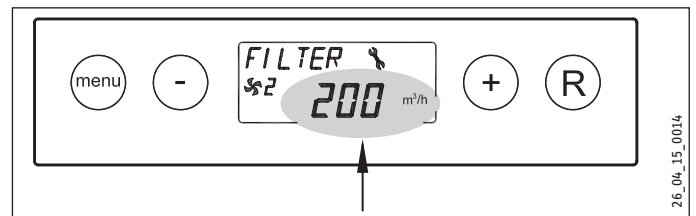

The selected air flow rate of the supply air and extract air fans is displayed.

If the air flow rates of the supply air and extract air fans differ, e.g. when an external switching contact is used, the highest air flow rate is always displayed.

When the appliance is switched off via software, the text "OFF" appears.

4.5.3 Message texts in standard mode

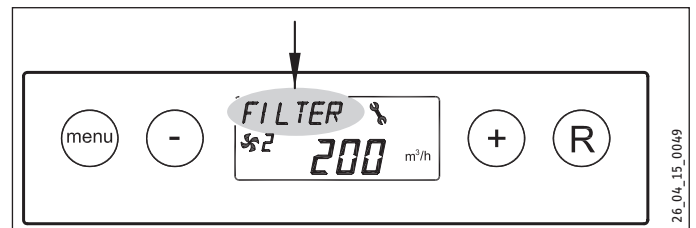

At this point on the display, a message text may appear. The message text "FILTER" always takes priority over other message texts.

OPERATION

Maintenance, cleaning and care

Message text	Description
FILTER	

If FILTER is displayed, the filter must be cleaned or replaced.

EWT	
-----	---

If EWT is displayed, the geothermal heat exchanger is enabled.

CN1 or CN2	
------------	---

If CN1 or CN2 is displayed, one of the external switching inputs is enabled.

V1 or V2	
----------	---

If V1 or V2 is displayed, one of the 0-10 V inputs is enabled.

Only when connection X1 is used (eBUS or OpenTherm connection):

Message text	Description
Slave 1, Slave 2, etc.	Master appliance: 

Slave appliance:	
------------------	---

With connected appliances, the message text indicates which appliance is the "Slave 1" to "Slave 9". The default display for fan operation is indicated on the master appliance.

5. Maintenance, cleaning and care

Maintenance by the user is limited to filter cleaning or replacement required at certain intervals.

5.1 Replacement filter

Product name	Part number	Description	Classification in accordance with ISO 16890
FMS G4-10	232475	Coarse particle filter mat G4; 10 pce per packing unit	ISO Coarse > 60 % (G4)
FMS F5-2	232476	Fine filter F5; 2 pce per packing unit	ePM ₁₀ ≥ 50 % (M5)
FMS F7-2	232477	Fine filter F7; 2 pce per packing unit	ePM ₁ ≥ 50% (F7)

5.2 Cleaning filters

Filters must be cleaned when "FILTER" is displayed.

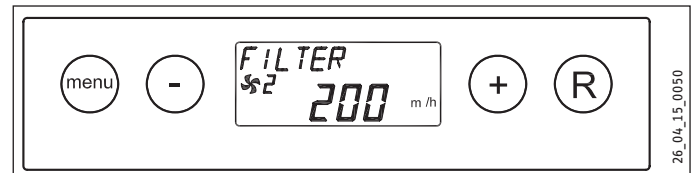

Replace filters annually.

Never operate the appliance without filters.

Cleaning or replacing filters

- ▶ Press and hold down the minus button for 5 seconds to switch off the appliance.

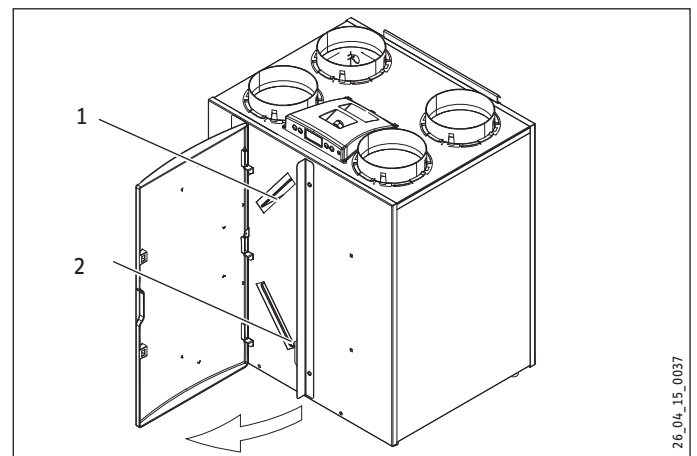

- 1 Extract air filter
 - 2 Supply air filter
- ▶ Open the filter door.

OPERATION

Maintenance, cleaning and care

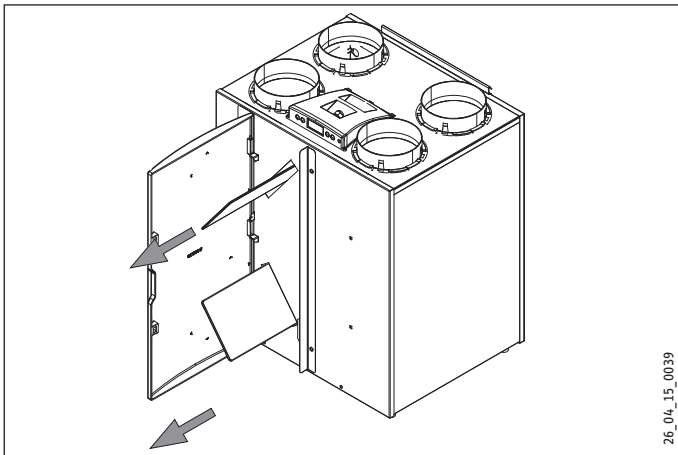

- ▶ Extract the supply air and extract air filters. Make a note of how the filters were fitted.

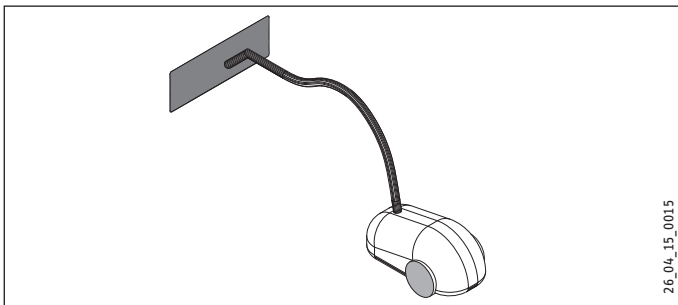

- ▶ Clean the filters, e.g. with a vacuum cleaner.

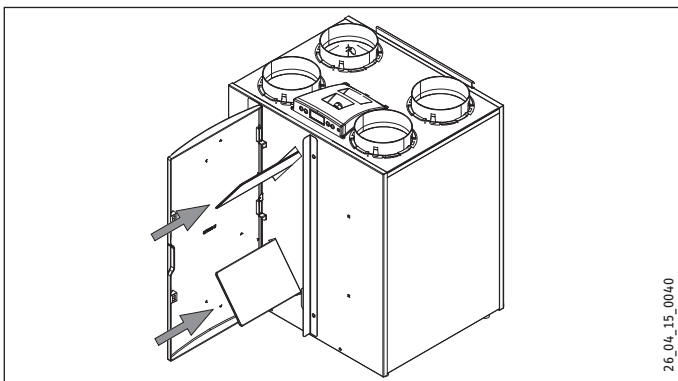

- ▶ Push the cleaned or new filter into the appliance.

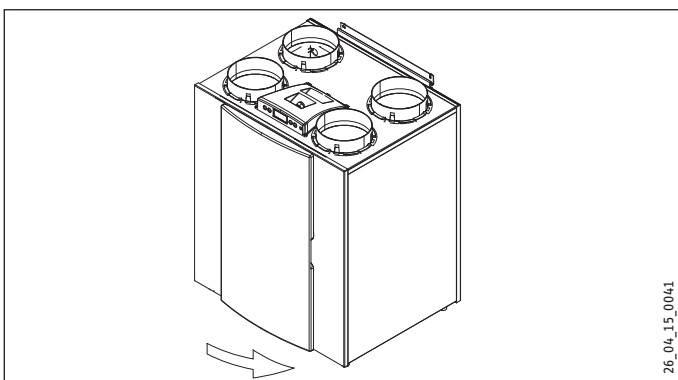

- ▶ Close the filter door.

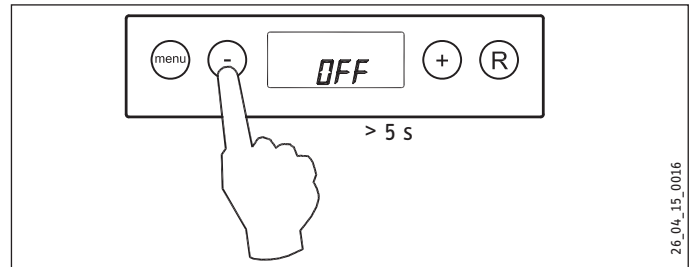

- ▶ Switch on the appliance by pressing the minus button for 5 seconds.

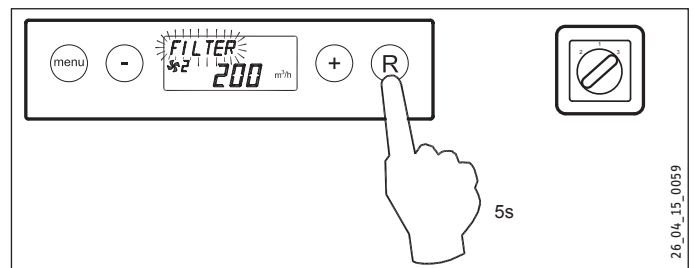

- ▶ After cleaning or replacing the filters, hold down the R key for 5 seconds to reset the filter display.

To confirm that the filters have been reset, the text "FILTER" will flash briefly. Even if the message "FILTER" has not yet been displayed, it is possible to reset the filter. The counter is then reset to zero.

Once the filter has been reset, the text "FILTER" disappears and standard mode is displayed again.

6. Troubleshooting

6.1 Fault analysis

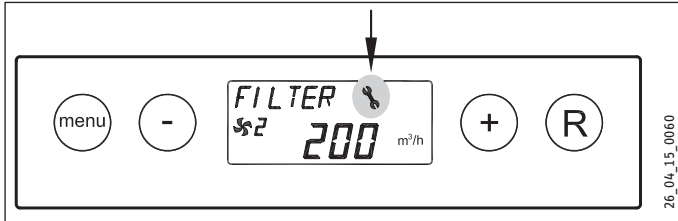

If the appliance detects a fault, a flashing fault symbol (spanner) is displayed, possibly together with a fault number.

The appliance differentiates between a fault, where the appliance continues to operate with limited functionality, and a blocking fault, where both fans are stopped.

In the event of a blocking fault, the settings and read-out menus are also switched off and access is restricted to the service menu.

The appliance remains in this fault condition until the problem has been resolved. The appliance then resets itself (auto reset) and standard mode is displayed again.

6.2 Fault codes

Non-blocking fault

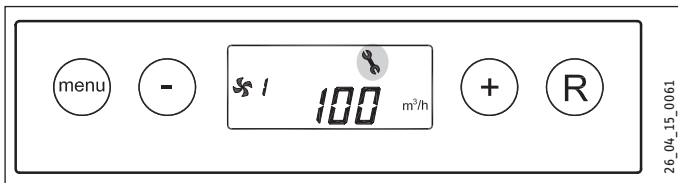

If the appliance detects a non-blocking fault code, it continues to operate with limited functionality. Non-blocking faults are displayed with the fault symbol (spanner).

Blocking fault

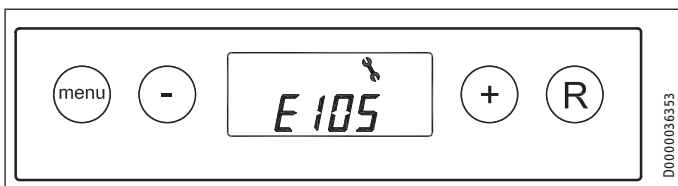

If the appliance detects a blocking fault code, it stops. The permanently illuminated display shows the fault symbol (spanner) together with a fault code.

► Notify a qualified contractor, who can correct the fault.

A blocking fault cannot be resolved by briefly disconnecting the appliance from the power supply. The fault itself must first be rectified.

If you cannot remedy the fault, notify your qualified contractor. To facilitate and speed up your request, provide the number from the type plate (000000-0000-000000).

INSTALLATION

7. Safety

Only a qualified contractor should carry out installation, commissioning, maintenance and repair of the appliance.

7.1 General safety instructions

We guarantee trouble-free function and operational reliability only if original accessories and spare parts intended for the appliance are used.

7.2 Instructions, standards and regulations



Note

Observe all applicable national and regional regulations and instructions.



WARNING Injury

In connection with the fire prevention regulations concerning the installation of ventilation systems, observe all country-specific regulations and requirements. In Germany, these are particularly the building regulation guideline on fire prevention requirements of ventilation systems in its applicable version.

7.3 Operation of the appliance in buildings with combustion equipment

The term “combustion equipment” used below includes, for example, tiled stoves, fireplaces and equipment with gas combustion.



WARNING Injury

Ventilation units can generate negative pressure in the dwelling. If combustion equipment is operating at the same time, combustion exhaust gases can penetrate the room where the combustion equipment is installed. It is therefore important to observe a number of points for simultaneous operation of a ventilation unit and combustion equipment.

The engineering, installation and operation of the ventilation unit and combustion equipment must be carried out in accordance with national and regional regulations.

7.3.1 Planning safety measures

Together with the relevant authorities, engineers plan the safety measures that are required for simultaneous operation of a ventilation unit and combustion equipment.

Alternate operation

Alternate operation means that, when the combustion equipment is started, the mechanical ventilation system is switched off and/or cannot be started. Alternate operation must be ensured by appropriate measures, e.g. automatically enforced shutdown of the ventilation unit.

Simultaneous operation

For simultaneous operation of combustion equipment and a mechanical ventilation system, we recommend choosing approved room sealed combustion equipment (in Germany, with DIBt approval).

If open flue combustion equipment is operated in the dwelling at the same time as a ventilation unit, combustion exhaust gases must be prevented from penetrating the home as a result of possible negative pressure in the room.

The ventilation unit may only be operated in combination with intrinsically safe combustion equipment. This combustion equipment has, for example, a draught hood or an exhaust gas monitor and is permitted to be operated in conjunction with ventilation units. Alternatively, external, tested safety equipment can be connected to monitor the operation of the combustion equipment. For example, you can install differential pressure monitoring to monitor the chimney draught and to switch off the ventilation unit in the event of a fault.

The equipment for differential pressure monitoring must fulfil the following requirements:

- Monitoring of the differential pressure between the connection piece to the chimney and the room where the combustion equipment is installed
- Possibility of matching the shutdown value for the differential pressure to the minimum draught requirement for the combustion equipment
- Floating contact to switch off ventilation
- Optional connection of a temperature capturing device so that differential pressure monitoring is only enabled when the combustion equipment is in operation and so that unwanted shutdowns due to environmental influences can be avoided



Note

Differential pressure switches that use the pressure differential between the outdoor air pressure and the pressure in the room where the combustion equipment is sited as a response criterion are not suitable.



Note

We recommend installing and regularly maintaining a carbon monoxide detector in accordance with EN 50291 for operation of any combustion equipment.

7.3.2 Commissioning

When commissioning the ventilation unit, it is important to check and document in the commissioning log that combustion exhaust gases are not penetrating the dwelling in a quantity that is harmful to health.

Commissioning in Germany

Acceptance is carried out by the local flue gas inspector.

Commissioning outside Germany

Acceptance must be carried out by a specialist. In case of doubt, you must involve an independent expert in the acceptance procedure.

7.3.3 Maintenance

Regular maintenance of the combustion equipment is prescribed. Maintenance includes checking the exhaust gas extraction system, the free pipe cross-sections and the safety equipment. The relevant qualified contractor responsible must prove that there is a sufficient flow of combustion air.

7.4 Operating the appliance in passive houses

If operating the appliance in a passive house, the factory-fitted outdoor air filter must be replaced. See chapter "Appliance description / Accessories".

8. Appliance description

8.1 Standard delivery

The following are delivered with the appliance:

- Wall mounting bracket set (2 mounting brackets, 3 protective caps, 1 rubber strip, 2 rubber rings, 1 set of installation instructions)
- PVC condensate drain connection (1 plastic nut 1.5", 1 sealing ring, 1 glued joint PVC fitting 32 mm)
- Approx. 90 cm long cable for connecting a remote control

8.2 Required accessories

- Hardwired remote control used to control the air flow rates preset in three stages. Our range of accessories includes remote control units with additional functions.

8.3 Further accessories

You can also obtain ventilation pipes, extract air and supply air valves and similar accessories from us.

9. Preparations

9.1 Installation site

The appliance can be mounted on the wall with the wall mounting bracket set supplied.



Material losses

For vibration-free mounting, a solid wall with a minimum mass of 200 kg/m² is required. A plaster board or metal framed wall is inadequate. Additional measures such as a double skin or additional supports would be needed in such cases.

Ensure the equipment is level after installation.

The installation site must have an adequate condensate drain with stench trap and a fall for the condensate.

The installation site must be free from the risk of frost.

9.2 Transport

To protect the appliance against damage, you should transport it to the installation room inside its original packaging.

10. Installation

10.1 Mounting the appliance

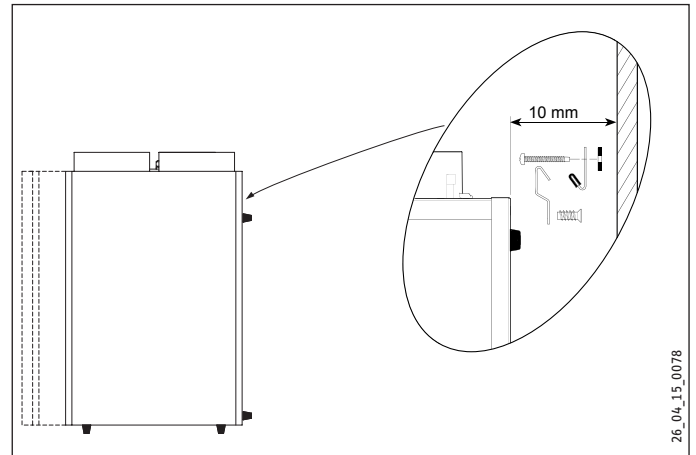

- ▶ Undo the two top crosshead screws on the back of the appliance.
- ▶ Secure one of the two rails to the appliance with screws.



Material losses

- ▶ Check whether the wall can bear the weight of the appliance.
- ▶ Use appropriate rawl plugs and screws suitable for the wall structure to attach the rail.

- ▶ Mount the second rail on the wall as a retainer. To avoid sound transmission, place the washers supplied between the wall and the rail.
- ▶ Affix the spacers supplied to the back of the appliance.

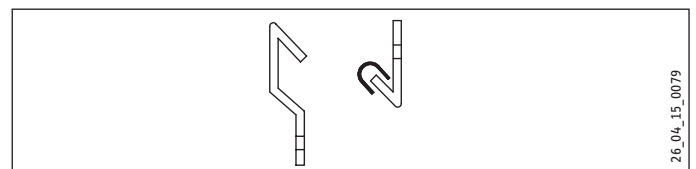

- ▶ Place the rubber strips supplied on the rail mounted on the wall. The rubber strips are also meant to provide additional anti-vibration separation.
- ▶ Fit the appliance so that the two rails interlock.

10.2 Connecting the condensate drain



Material losses

Never kink the hose, to ensure the condensate drains perfectly. The fall must be at least 10 %, and the appliance must be horizontal.

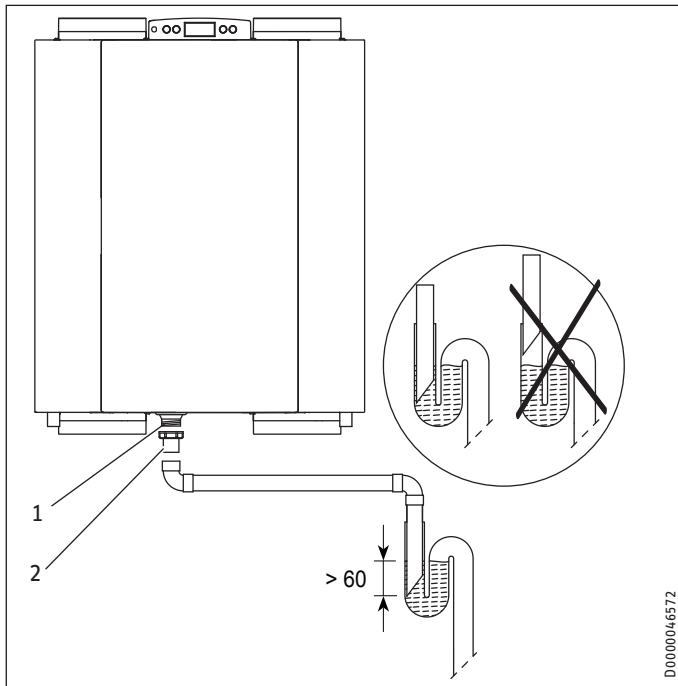

- 1 Condensate drain
- 2 Condensate drain connector (Ø 32 mm) with union nut

The condensate drain is routed through the floor plate. The condensate must drain away via the domestic sewer system.

- Secure the condensate drain connector supplied along with the gasket and union nut to the condensate drain located underneath the appliance.

You can fit the condensate drain pipe (bent if required) to this condensate drain connector with a glued joint.

- Before connecting the condensate drain to the appliance, pour water into the siphon to create a stench trap.

The condensate drain pipe must terminate below the water level in the siphon. The condensate drain pipe must be immersed in the water in the siphon by at least 60 mm.

10.3 Connecting air ducts

During installation, ensure that no metal swarf enters the ductwork. However, should this occur, remove this debris, otherwise the fans may be damaged.

External wall ducts

Supply outdoor air from a location where contamination (dust, soot, odours, flue gas, exhaust air) is as low as possible.

When installing external wall ducts, prevent any short circuit between the air intake and the air discharge.

Silencers

Always install a silencer in both the supply air duct and the extract air duct. We recommend installing additional silencers if required to avoid sound transmission.

If a room with a high noise level must be ventilated, install additional silencers upstream of this room to reduce sound transmission to adjacent rooms.

Aspects such as carried voices and impact sound must also be taken into consideration in the case of ducts embedded in concrete. Carried voices should be avoided by designing the duct with separate branches to the valves. If required, insulate the supply air ducts, e.g. if they are outside the insulated wall panel.

Overflow apertures

In living rooms and bedrooms, air is only blown in. Air is only extracted from rooms where odours and moisture are generated. Ventilation grilles must be installed in internal doors or walls, or the air gap beneath the door must be increased to ≥ 8 mm to ensure an unobstructed air flow.

Insulation against condensation



Material losses

When warm air meets cold surfaces, condensation can result.

- For outdoor air and exhaust air ducts, use vapour-proof thermally insulated pipes.
- If you use uninsulated pipes and moulded parts for this pipework, ensure that they are adequately insulated.
- Insulate the supply air and extract air ducts if they are routed through unheated rooms.

The extract air duct does not require a control valve, because the necessary air flow rates are controlled by the appliance itself.

INSTALLATION

Installation

10.4 Power supply



WARNING Electrocutation

Carry out all electrical connection and installation work in accordance with national and regional regulations.



WARNING Electrocutation

Before connecting the appliance to the mains power supply, isolate all power cables. Isolation from the mains power supply must be carried out with a contact separation of at least 3 mm, e.g. by means of omnipolar isolators.

The appliance can be connected at a socket using the plug fitted to the appliance.

Take the power consumption of the preheater coil into consideration.

10.4.1 Terminal X1 (Safety extra low voltage)

Connection for eBUS or OpenTherm plug-in connection

The appliance can operate with both an OpenTherm and an eBUS protocol. Provide the accessories required for this on site.

Subject to the setting of parameter 08 in the settings menu, you can choose between eBUS and OpenTherm.

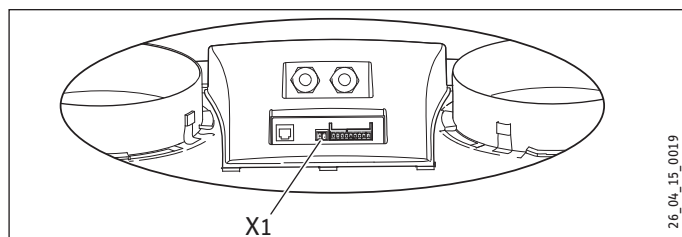

To connect an eBUS or OpenTherm connection, there is a 2-pole X1 connection on the back of the display cover.

The eBUS protocol can, for example, be used to link appliances (cascade control). In the context of sensitivity to polarity, always connect contacts X1-1 and X1-1, and contacts X1-2 and X1-2. If the contacts are interchanged, the appliance will not work.

With the OpenTherm protocol, swapping over the cable connection at the 2-pole screw connection X1 does not affect the functioning of the appliance.

The eBUS connection is set as default in parameter 08.

The X1 connection is only suitable for low voltage.

10.4.2 X2 connection (Safety extra low voltage)

Connecting a stage switch



Note

Route the stage switch cable and power cable for the ventilation unit separately.

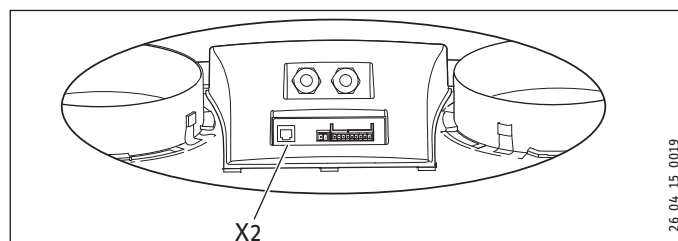

Connect the stage switch (not part of standard delivery) to the modular plug-in connection, type RJ12 (X2 connection). The X2 connection is on the back of the appliance's display cover.

A combination of stage switches is also possible. The X2 connection is only suitable for low voltage.

10.4.3 Connection X14

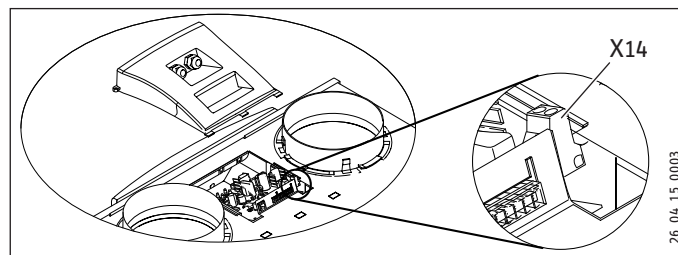

The X14 connection is used to connect an external reheater coil.

The 2-pole X14 connection can be accessed once you have removed the display cover. The display cover has a second union nut. This union nut enables any connected 230 V cable, which can be connected at X14, to be routed out of the appliance.

The X14 connection is disabled as default.

► If you connect a reheater coil, adjust parameter 13 in the settings menu.

The max. permissible connected load is 1000 W.

► If you connect a reheater coil, also connect the temperature sensor for the reheater coil across X15-7 and X15-8.

► Secure the power cable that is routed to the reheater coil using the strain relief below the display cover.

INSTALLATION

Installation

10.4.4 Connection X15 (Safety extra low voltage)

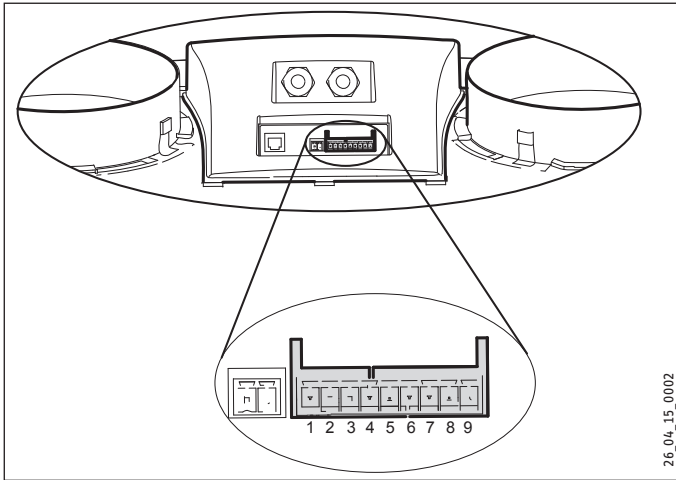

The 9-pole X15 terminal strip can be accessed on the back of the display cover without having to open the appliance.

Connection X14	Purpose	Parameter 15	Parameter 21
1 & 2	External switching contact	0	N/O contact (factory setting)
		1	0 - 10 V input; X15-1 = GND & X15-2 = 0 - 10 V
		2	N/C contact
		3	Switching input 1: Bypass open = 12 V; bypass closed = 0 V
		4	Switching input 1: Bypass open = 0 V; bypass closed = 12 V
3 & 4	Input 0 - 10 V	0	N/O contact
		1	0 - 10 V input (= factory setting)
		2	N/C contact
		3	Switching input 2: Bypass open = 12 V; bypass closed = 0 V
		4	Switching input 2: Bypass open = 0 V; bypass closed = 12 V
5 & 6	24 V connection		max. 4.5 V A; 5 = earth; 6 = +
7 & 8	Connection of sensor for reheat-er coil or outside temperature for geothermal heat exchanger		
9	Valve control signal (0 or 10 V)		9 = + ; 5 = earth

INSTALLATION

Installation

Connection of an external switching contact across X15-1 and X15-2

By adjusting parameter 18, when the input of "external switching contact 1 (X15-1 and X15-2)" is closed, you can set five different operating modes for the supply air and extract air fans. Subject to the setting for parameters 19 and 20, the supply air and extract air fans can deliver different air flow rates (maximum air flow rate is displayed).

Parameter 18	Function conditions	Supply air fan and extract air fan operating mode	Parameter 19	Parameter 20	Action, supply air or extract air fan when closing contact input X15-1 & X15-2
0	Contact input 1 (X15-1 & X15-2) closed	No action possible, because contact input 1 has not been enabled (parameter 18 is still on 0)			
1	Contact input 1 (X15-1 & X15-2) closed	Action dependent on the setting for the supply air fan (parameter 19) and the extract air fan (parameter 20)	0	0	Fan switches off
2	Contact input 1 (X15-1 & X15-2) closed; bypass conditions for "Damper open" are met		1	1	Fan on minimum air flow rate (50 m ³ /h)
			2	2	Fan on air flow rate stage 1
			3	3	Fan on air flow rate stage 2
			4	4	Fan on air flow rate stage 3
3	Contact input 1 (X15-1 & X15-2) closed	The bypass damper opens; automatic bypass control unit in the appliance is 'overridden'; action of the fans subject to parameters 19 and 20.	5	5	Fan on air flow rate step switch
4	Contact input X15-1 & X15-2 closed	The supply air diverter valve opens. The supply air diverter valve (24 V) is connected to X15-5 (24 V GND), X15-6 (24 V +) and X15-9 (0-10 V control unit); the action of the fans is subject to parameters 19 and 20.	6	6	Fan on max. air flow rate
			7	7	No fan control

If connections X15-3 and X15-4 are programmed as switching input 2, you can use parameters 24, 25 and 26 to set the individual operating modes similarly to contact input 1. When contact input 2 is closed, "CN2" is displayed.

10.4.5 Connection of safety equipment for operation of a stove/fireplace

Version 1: Connection of safety equipment at X15

- ▶ Close the safety equipment floating contact for stove/fireplace operation at X15-1 and X15-2.
- ▶ Set parameter 18 to 1, and parameters 19 and 20 to 0. If the safety equipment closes the power circuit across X15-1 and X15-2, the extract air fan and the supply air fan are switched off.

Version 2: Power supply interruption through safety equipment

- ▶ Connect the safety equipment in accordance with the diagram in chapter "Electrical connection / Standard circuit".

INSTALLATION

Installation

10.4.6 Standard circuit

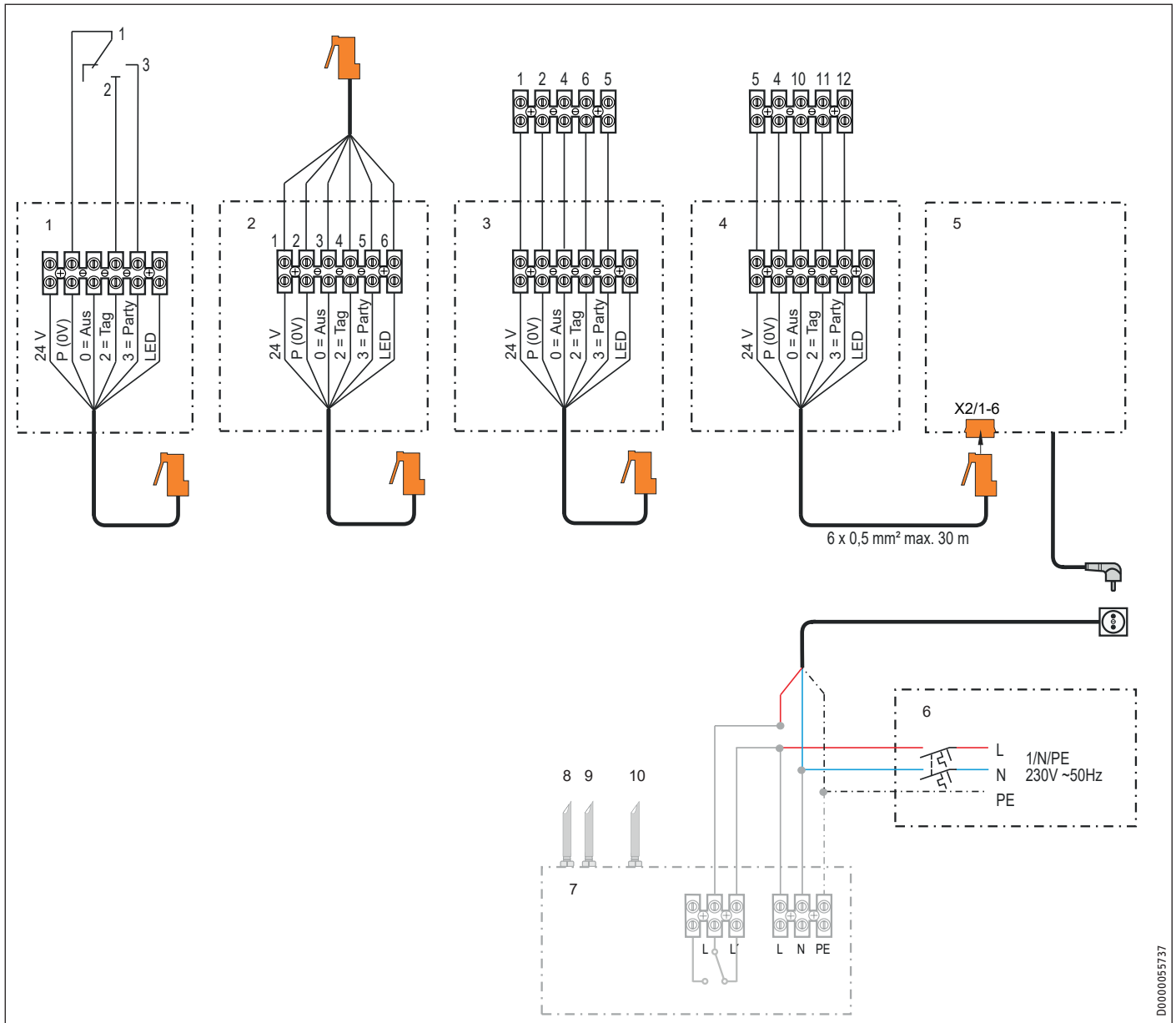

- 1 3-stage switch
- 2 4-stage switch
- 3 Air quality sensor FEQ
- 4 Remote control FEZ
- 5 Ventilation unit
- 6 Power supply, domestic electricity meter
- 7 Differential pressure switch, combustion equipment
- 8 Pressure connection "stove"
- 9 Pressure connection "room"
- 10 Flue gas temperature sensor

D0000055737

INSTALLATION

Commissioning

11. Commissioning







WARNING Injury
If the unit is switched on without the air ducts connected and someone reaches through the air connectors into the unit, there is a risk of injury.
Do not commission the unit until the air ducts are firmly connected to it.

11.1 Initial start-up

11.1.1 Setting the air flow rate

Output and energy consumption of the appliance depend on the pressure drop in the duct system and the resistance of the filters.

Fan stage	Air flow rate
 0	m ³ /h
	50: Moisture protection ventilation This fan stage prevents mould formation using the factory-set air flow rate of 50 m ³ /h.
 1	m ³ /h
	must be lower than for stage 2
 2	m ³ /h
	must be lower than for stage 3
 3	m ³ /h
	LWZ 370 plus: 50 - 400
	LWZ 170 E plus: 50 - 300

The air flow rate of the higher fan stage is automatically selected if one of the above conditions is not met.

11.2 Shutdown

Even during longer periods away from home, we recommended that the equipment should be allowed, via the remote control, to run at switch position 1. If you nevertheless need to take the appliance out of use for an extended period, switch it off via the user interface and unplug it from the mains to isolate it from the power supply.

- ▶ Clean or replace filters.

11.3 Recommissioning

- ▶ Check whether filters are fitted in the appliance. Never start the appliance without filters.
- ▶ Check whether the condensate drain is damaged or kinked.

12. Settings

12.1 Settings menu

For optimum appliance function, you can change parameters used to adapt the appliance to the actual installation. Some parameter settings such as the air flow rates have been set out in the technical details appertaining your individual building.



Note
Changes to settings not described may only be made by agreement with the manufacturer. Incorrect settings may impair the correct appliance function.

12.1.1 How to set parameters

Selecting the settings menu

- ▶ Press menu in standard mode.

The settings menu is displayed ("SET").

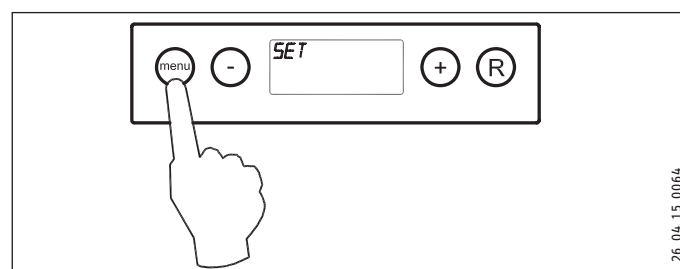

Enabling the settings menu

- ▶ Press menu again to enable the settings menu.

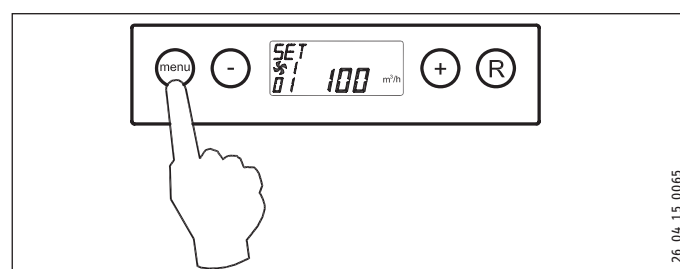

Selecting parameters

- ▶ Use the plus or minus key to select the parameter you want to set.

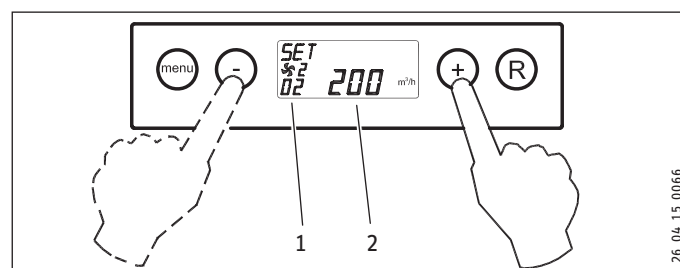

- 1 Parameter number
- 2 Parameter value

INSTALLATION

Settings

Parameter change

- ▶ Press menu.

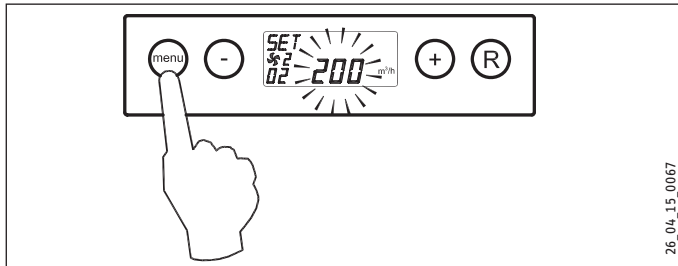

- ▶ The parameter value starts to flash.
- ▶ Use plus or minus to change the parameter value.

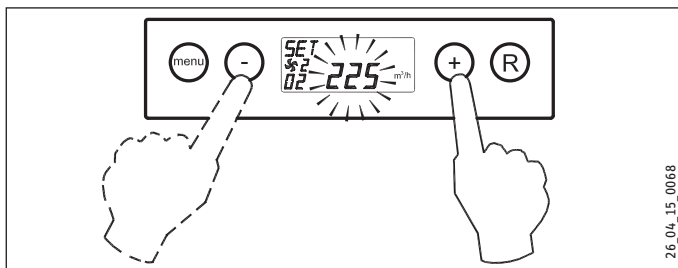

Discarding a parameter change

- ▶ If you do not want to save the changed parameter value, press R.

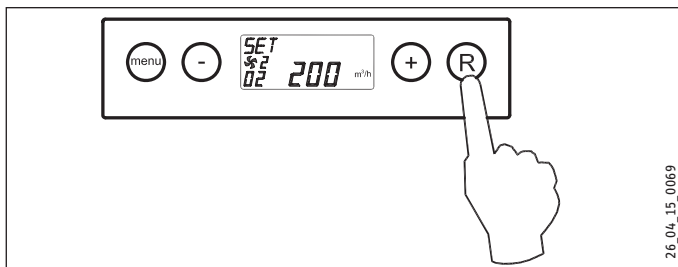

Confirm parameter value

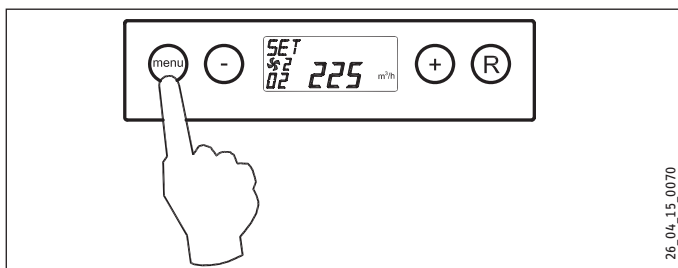

- ▶ If you want to save the changed parameter value, press menu.



















Note

To change other parameters, repeat the steps described from "Selecting parameters". If you do not want to change any more parameters, press R to return to standard mode.

INSTALLATION









Settings

12.1.2 List of parameters in the settings menu

Parameter	Description	Unit	Factory setting	Setting range	Step size	Display text and symbols
01	Air flow rate of stage 	m ³ /h	50	0 50: Moisture protection ventilation		
02	Air flow rate of stage 1	m ³ /h	100	LWZ 370 plus: 50 - 400 LWZ 170 E plus: 50 - 300	5	 1
03	Air flow rate of stage 2	m ³ /h	LWZ 370 plus: 200 LWZ 170 E plus: 150	LWZ 370 plus: 50 - 400 LWZ 170 E plus: 50 - 300	5	 2
04	Air flow rate of stage 3	m ³ /h	LWZ 370 plus: 300 LWZ 170 E plus: 225	LWZ 370 plus: 50 - 400 LWZ 170 E plus: 50 - 300	5	 3
05	Bypass temperature	°C	22	15 - 35	0.5	BYPASS 
06	Bypass hysteresis	°C	2	0 - 5	0.5	BY HYS 
07	Bypass damper function		0	0 (Automatic function) 1 (Bypass damper closed) 2 (Bypass damper open)		BYPASS 
08	Communication		eBUS	OT (OpenTherm) eBUS		OT/BUS
09	BUS address		0	0 - 9 (0 = master)		BUSADR
10	Introduction of an additional extract air flow.		OFF	As default, this parameter must remain OFF for this appliance.		CV+WTW
11	Pressure imbalance permissible		ON	OFF (Air flow rate for supply/extract air the same) ON (Pressure imbalance permissible)		 
12	Fixed pressure imbalance	m ³ /h	0	-100 - 100	1	 
13	Heating coils		0	0 (Aus) 1 (Preheater coil) 2 (Reheater coil)		HEATER 
14	Reheater coil temperature	°C	21	15 - 30	0.5	HEATER 
15	Selection, switching input 1		0	0 (N/O contact) 1 (0 - 10 V input) 2 (N/C contact) 3 (Bypass open = 12 V; bypass closed = 0 V) 4 (Bypass open = 0 V; bypass closed = 12 V)		V1
16	Minimum voltage, switching input 1	V	0	0 - 10	0.5	V1 MIN
17	Maximum voltage, switching input 1	V	10	0 - 10	0.5	V1 MAX
18	Conditions, switching input 1		0	0 (Aus) 1 (Ein) 2 (On, if conditions for open bypass are met) 3 (Bypass control) 4 (Supply air diverter valve)		CN1
19	Supply air fan mode, switching input 1		5	0 (Supply air fan off) 1 (Absolute minimum air flow rate 50 m ³ /h) 2 (Air flow rate stage 1) 3 (Air flow rate stage 2) 4 (Air flow rate stage 3) 5 (Step switch) 6 (Max. air flow rate) 7 (No supply air fan control)		CN1  

INSTALLATION

Settings

Parameter	Description	Unit	Factory setting	Setting range	Step size	Display text and symbols
20	Extract air fan mode, switching input 1		5	0 (Extract air fan off) 1 (Absolute minimum air flow rate 50 m ³ /h) 2 (Air flow rate stage 1) 3 (Air flow rate stage 2) 4 (Air flow rate stage 3) 5 (Step switch) 6 (Max. air flow rate) 7 (No extract air fan control)		CN1  
21	Selection, switching input 2		1	0 (N/O contact) 1 (0 - 10 V input) 2 (N/C contact) 3 (Bypass open = 12 V; bypass closed = 0 V) 4 (Bypass open = 0 V; bypass closed = 12 V)		V2
22	Minimum voltage, switching input 2	V	0	0 - 10	0.5	V2 MIN
23	Maximum voltage, switching input 2	V	10	0 - 10	0.5	V2 MAX
24	Conditions, switching input 2		0	0 (Aus) 1 (Ein) 2 (On, if conditions for open bypass are met) 3 (Bypass control) 4 (Supply air diverter valve)		CN2
25	Supply air fan mode, switching input 2		5	0 (Supply air fan off) 1 (Absolute minimum air flow rate 50 m ³ /h) 2 (Air flow rate stage 1) 3 (Air flow rate stage 2) 4 (Air flow rate stage 3) 5 (Step switch) 6 (Max. air flow rate) 7 (No supply air fan control)		CN2  
26	Extract air fan mode, switching input 2		5	0 (Extract air fan off) 1 (Absolute minimum air flow rate 50 m ³ /h) 2 (Air flow rate stage 1) 3 (Air flow rate stage 2) 4 (Air flow rate stage 3) 5 (Step switch) 6 (Max. air flow rate) 7 (No extract air fan control)		CN2  
27	Geothermal heat exchanger		OFF	OFF (Valve control for geothermal heat exchanger off) ON (= Valve control for geothermal heat exchanger on)		EWT
28	Minimum temperature for geothermal heat exchanger (below this temperature, the valve opens)	°C	5	0 - 10	0.5	EWT T- 
29	Maximum temperature for geothermal heat exchanger (above this temperature, the valve opens)	°C	25	15 - 40	0.5	EWT T+ 

INSTALLATION

Settings

12.2 Read-out menu

With the read-out menu, you can call up some values for more detailed information on the function of the appliance. Values and settings cannot be changed in the read-out menu.

► Press menu in standard mode.

The settings menu is displayed ("SET").

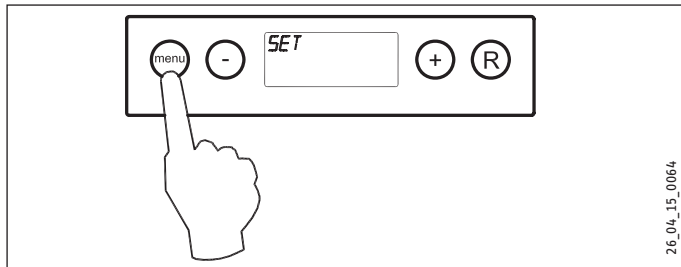

► Press plus or minus to switch to the read-out menu.

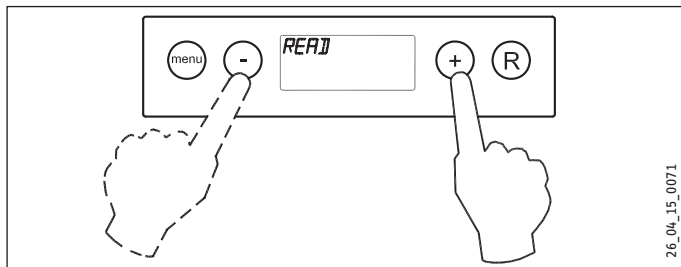

► Press menu to enable the read-out menu.

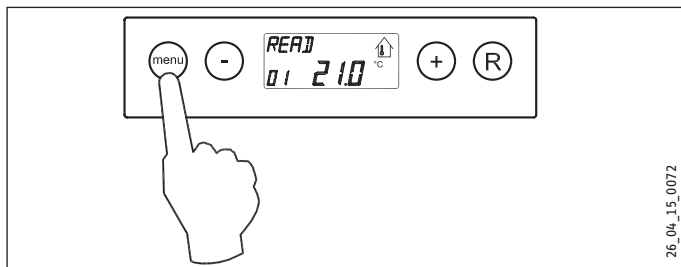

Use plus or minus in the read-out menu to move to the required parameter.

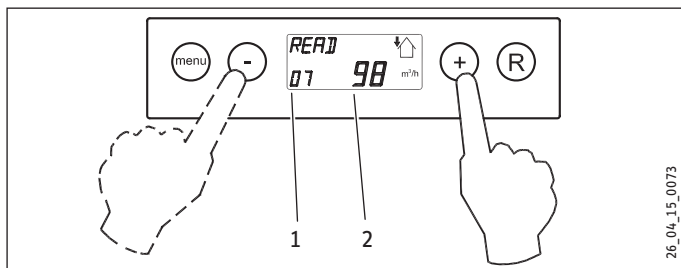

Parameter	Description of the actual value	Unit
01	Room temperature	°C
02	Outside temperature (captured by the outside temperature sensor)	°C
03	Bypass status (ON = Bypass damper open, OFF = Bypass damper closed)	
04	Frost protection status (ON = Frost protection enabled, OFF = Frost protection disabled)	
05	Supply air duct pressure	Pa
06	Extract air duct pressure	Pa
07	Air flow rate of supply air fan	m³/h
08	Air flow rate of extract air fan	m³/h

► Press R twice to return to standard mode.

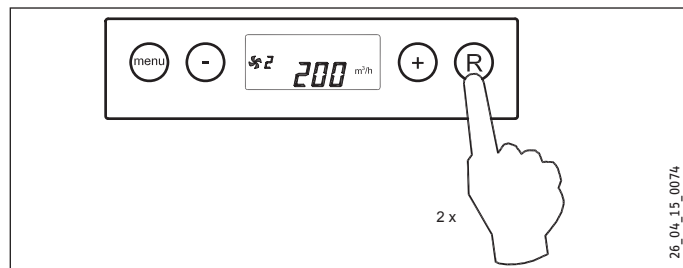

If no key is pressed for 5 minutes, the appliance returns automatically to standard mode.

12.3 Service menu

In the service menu, you can view the last 10 fault messages.

In the case of blocking faults, the settings menu and the read-out menu are blocked and only the service menu can be accessed. Pressing menu opens the service menu.

Viewing the service menu

► Press menu in standard mode. The settings menu is displayed.

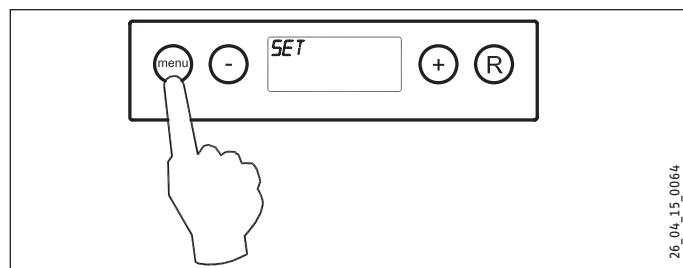

► Press plus or minus to switch to the read-out menu.

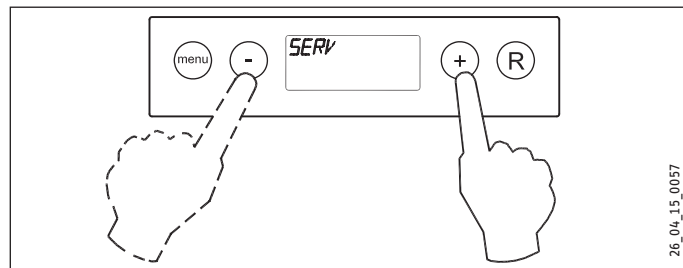

► Press menu to enable the service menu.

INSTALLATION

Settings

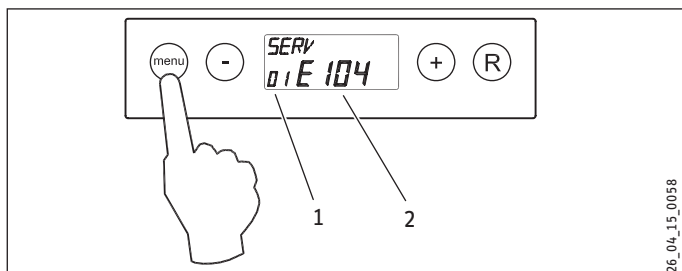

- 1 Fault message number
- 2 Fault code

You can use plus and minus to scroll through the read-out menu.

Indication "No fault message"



Current fault message (fault symbol on the display)

For fault messages with a cause that has not yet been eliminated, the fault symbol (spanner) appears.

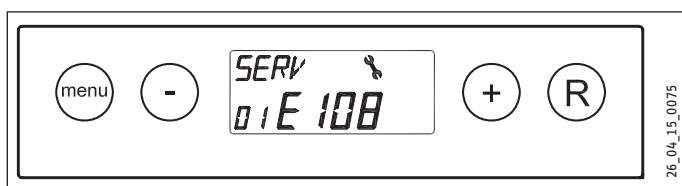

Resolved fault message (no fault symbol on the display)

For fault messages with a caused that has been eliminated, the fault symbol (spanner) does not appear.

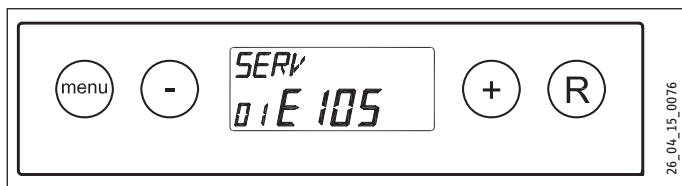

Back to standard mode

► Press R twice to return to standard mode.

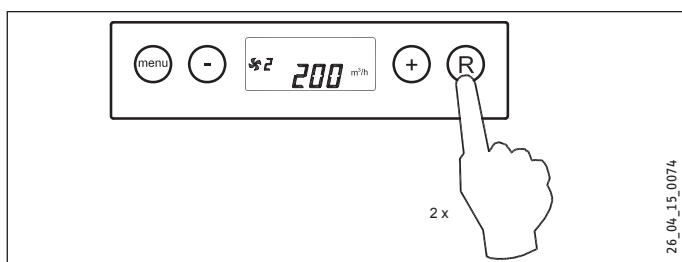

Deleting fault messages

You can delete all fault messages by holding down R for five seconds. This is only possible if there are no active faults.

12.4 Restoring factory settings

It is possible to reset all changed settings simultaneously to factory settings.

All changed settings revert back to their defaults as delivered from the factory; all message/fault codes are also deleted from the service menu.

► Press plus and minus simultaneously and hold down for 10 seconds.

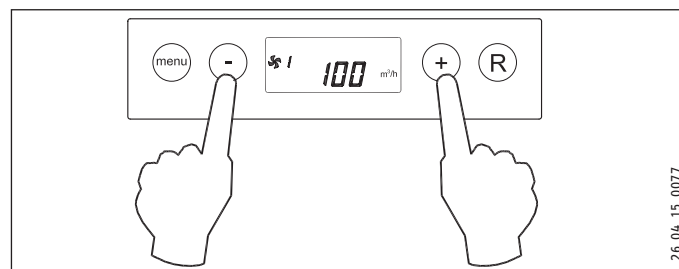

All display symbols light up for three seconds. The appliance is then in standard mode.

13. Maintenance



WARNING Electrocutation

In the event of damage to the power cable this must always be replaced by a qualified contractor authorised by the manufacturer, using original spare parts.

Maintenance by the qualified contractor includes the cleaning of the cross-countercurrent heat exchanger and the fans.

Subject to runtime, this maintenance work should be carried out every 3 years.

- ▶ Switch off the appliance by pressing the minus key for 5 seconds.
- ▶ Disconnect the power supply.
- ▶ Open the filter door.
- ▶ Extract the filters. Make a note of how the filters were fitted.

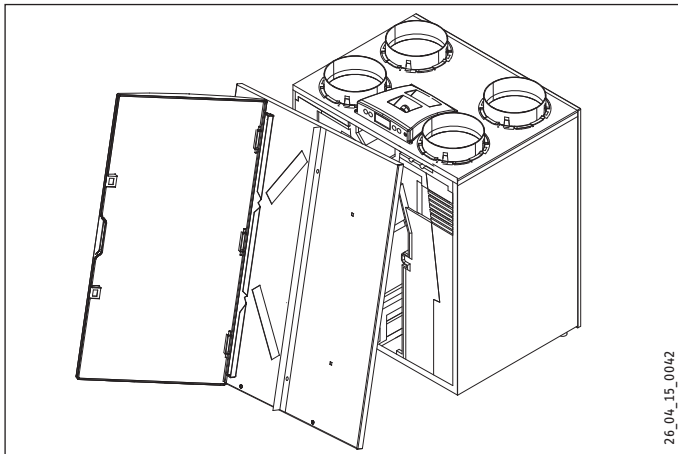

- ▶ Remove the front cover.

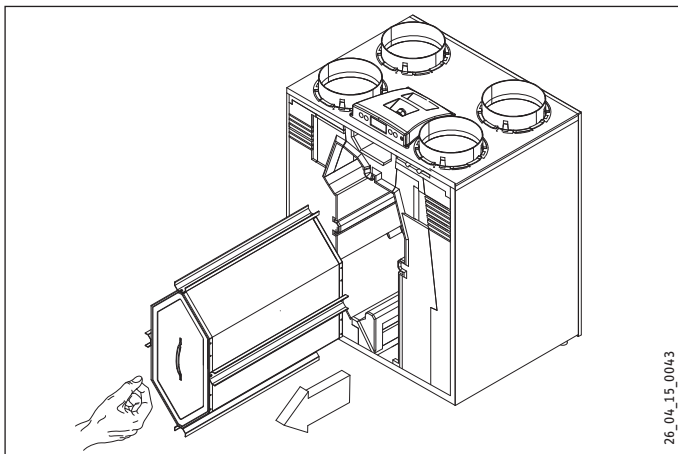

- ▶ Carefully remove the heat exchanger from the appliance. Avoid damaging the foam parts in the appliance.

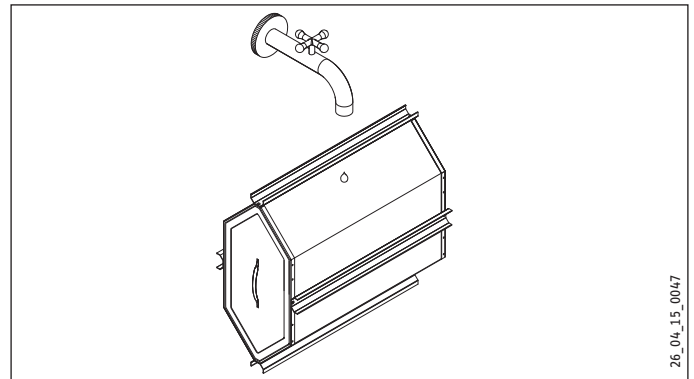

- ▶ Use a commercially available vacuum cleaner to remove dust and other loose dirt particles from the intake and discharge surfaces.
- ▶ If required, clean the heat exchanger with warm water (max. 55 °C) and a commercially available detergent. Never use solvents.
- ▶ Afterwards flush the heat exchanger with water.
- ▶ Remove the plug-in connections from the back of the display cover.

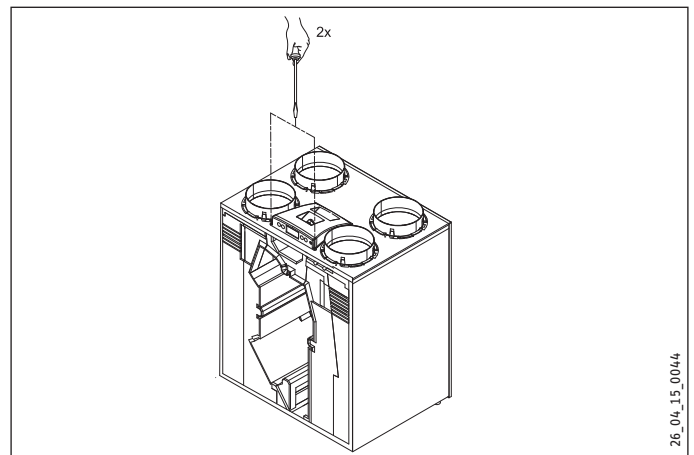

- ▶ Undo both screws securing the display cover to the appliance.

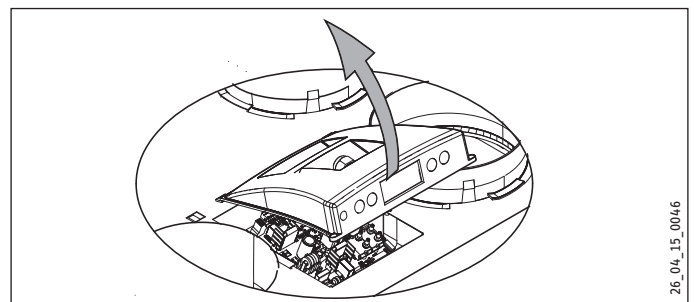

- ▶ Remove the display cover.
- ▶ Disconnect the 4 pressure hoses and 3 plug-in connections from the PCB.

INSTALLATION

Maintenance

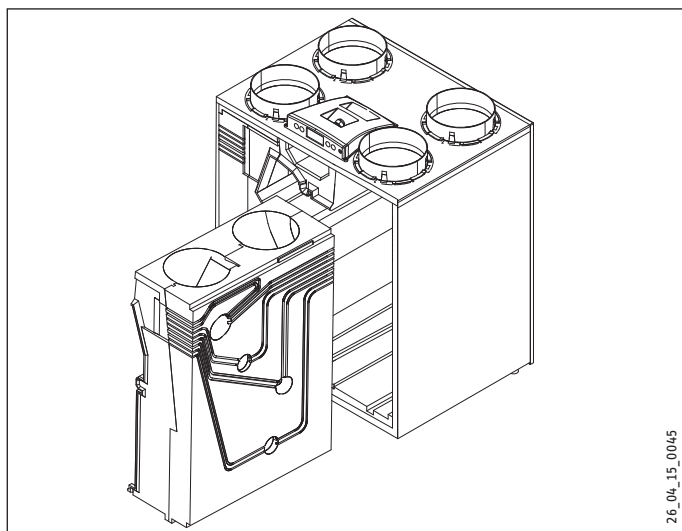

26_04_15_0045

- ▶ Extract the fan unit from the appliance.

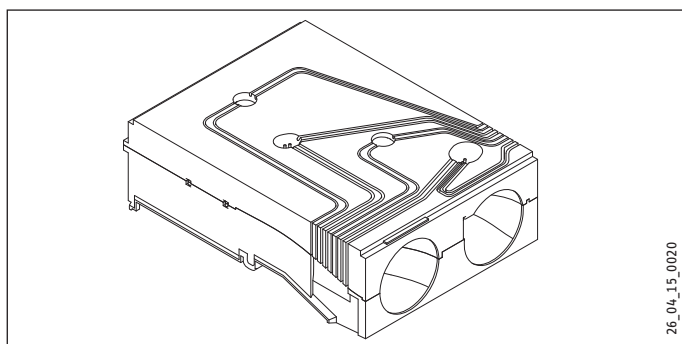

26_04_15_0020

- ▶ Place the fan unit on a flat surface with the pressure hoses facing up.
- ▶ Pull the red and blue pressure hose (without a black mark) out of the pressure tubes inside the fan unit. Ensure that no dirt drops into the pressure tubes.
- ▶ Rotate the foam part so that the pressure hoses are pointing down.

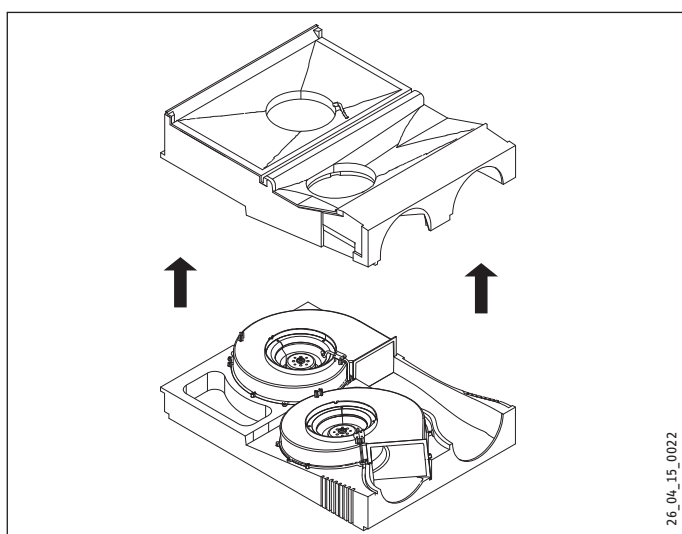

26_04_15_0022

- ▶ Carefully remove the top EPS insulation semi-shell so that both fans are accessible. Ensure that the fans remain in the lower EPS insulation semi-shell.

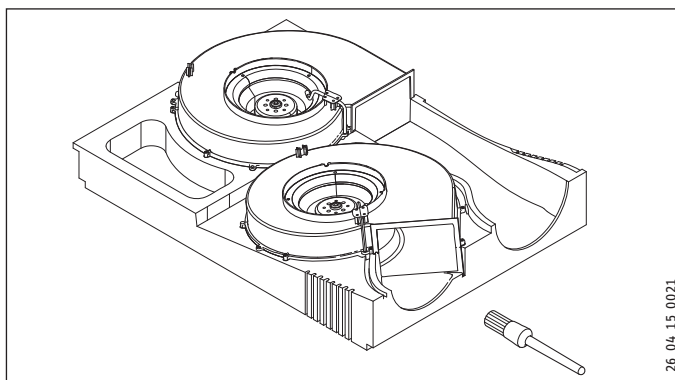

26_04_15_0021

- ▶ Clean the fans with a soft brush. Never displace the pressure compensation weights.
- ▶ Replace the top EPS insulation semi-shell over the fans.
- ▶ Reconnect the pressure hoses to the pressure tubes. Ensure that no dirt drops into the pressure tubes.
- ▶ Reinstall the complete fan unit in the appliance.
- ▶ Reconnect the pressure hoses and fan cables to the PCB. Ensure that the pressure hoses are positioned correctly on the marking labels on the pressure sensors. Observe the label in the appliance for correctly positioning the plug-in connections.
- ▶ Fit the display cover.
- ▶ Reconnect the previously disconnected plugs at the back of the display cover.
- ▶ Slide the heat exchanger back into the appliance.
- ▶ Fit the front cover.
- ▶ Insert the filters, respectively with their clean sides facing towards the heat exchanger.
- ▶ Close the filter door.
- ▶ Switch on the power supply.
- ▶ Switch on the appliance using the user interface by holding down minus for 5 seconds.
- ▶ After cleaning the filter or installing a new filter, reset the filter status indicator by holding down R for 5 seconds.

Cleaning the air ducts

Air ducts should be checked and possibly cleaned at regular intervals. Releasing the air ducts from the appliance or over the extract air and supply air valves enables inspection and cleaning.

INSTALLATION

Troubleshooting

14. Troubleshooting

Fault code	Blocking fault	Cause	Appliance behaviour	Measure
E100	no	Supply air fan pressure sensor faulty. Red pressure hoses blocked or kinked.	Switches over to constant speed control. At an outside temperature below 0 °C, the preheater coil switches on.	Isolate the appliance from the power supply. Check the red pressure hoses (including pressure tubes) for dirt, kinks or damage.
E101	no	Extract air fan pressure sensor faulty. Blue pressure hoses blocked or kinked.	Switches over to constant speed control. At an outside temperature below 0 °C, the preheater coil switches on.	Isolate the appliance from the power supply. Check the blue pressure hoses (including pressure tubes) for dirt, kinks or damage.
E103	no	Bypass faulty.	None. If the power is too low, the stepper motor is not correctly connected or is faulty; if the power is too high, there is a short circuit in the cabling or the stepper motor.	Isolate the appliance from the power supply. Check the stepper motor connection. Replace the cabling or stepper motor if required.
E104	Yes	Extract air fan faulty	Both fans are switched off. The preheater coil is switched off. The reheater coil, if present, is switched off. Restarting occurs every 5 minutes.	Isolate the appliance from the power supply. Replace the extract air fan. Switch on the power supply to the appliance again. The fault is reset automatically. Check the cabling.
E105	Yes	Supply air fan faulty	Both fans are switched off. The preheater coil is switched off. The reheater coil, if present, is switched off. Restarting occurs every 5 minutes.	Isolate the appliance from the power supply. Replace the supply air fan. Switch on the power supply to the appliance again. The fault is reset automatically. Check the cabling.
E106	Yes	The temperature sensor for capturing the outside temperature is faulty.	Both fans are switched off. The preheater coil is switched off. Bypass closes and is blocked.	Isolate the appliance from the power supply. Replace the outside temperature sensor. Switch on the power supply to the appliance again. The fault is reset automatically.
E107	no	The temperature sensor for capturing the extract air temperature is faulty.	Bypass closes and is blocked.	Isolate the appliance from the power supply. Replace the room temperature sensor.
E108	no	If installed: The temperature sensor for capturing the outside temperature is faulty.	The reheater coil, if present, is switched off. The geothermal heat exchanger, if present, is switched off.	Replace the temperature sensor for the outside temperature.
E999	Yes	The microswitches on the control PCB are not set correctly.	The appliance does not operate; the red fault LEDs at the stage switch are also off.	Adjust the microswitches correctly.

Correct microswitch setting

- ▶ Check whether the microswitches on the control PCB are set correctly (see diagram). If message E999 is nevertheless displayed, replace the control PCB with a PCB of the correct type.

LWZ 370 plus

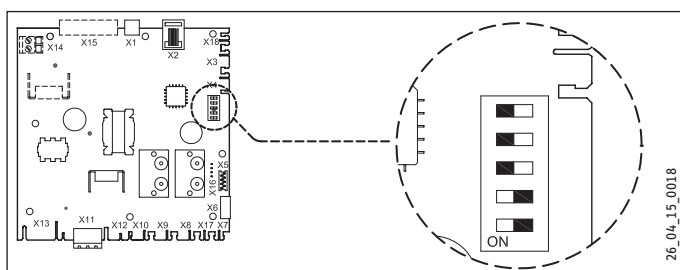

LWZ 170 E plus

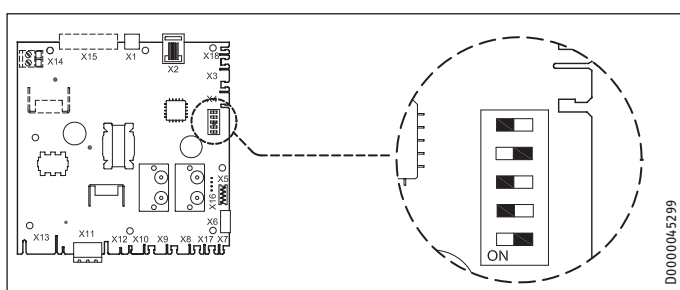

Stage switch modular connector

If stage 2 on a stage switch does not work, the modular connector of the stage switch is not connected correctly.

- ▶ Cut off one of the RJ plug-in connections to the stage switch and fit a new plug-in connection the other way round.

Pressure drop at the connections of the pressure hoses

For fan control, the appliance takes into account the pressure readings. The pressure sensors are fitted to the control PCB. Two pressure hoses are routed from each fan to the pressure sensors. If the pressure hoses are not connected correctly, leak or are blocked, pressure is captured incorrectly and the fans are therefore not correctly controlled.

- ▶ Check the connections of the pressure hoses if you have doubts about the correct functioning of the appliance.

15. Disposal

Removal

 **WARNING Electrocutation**
Disconnect the appliance from the power supply.

The following tools are required for disassembly and material separation prior to disposal:



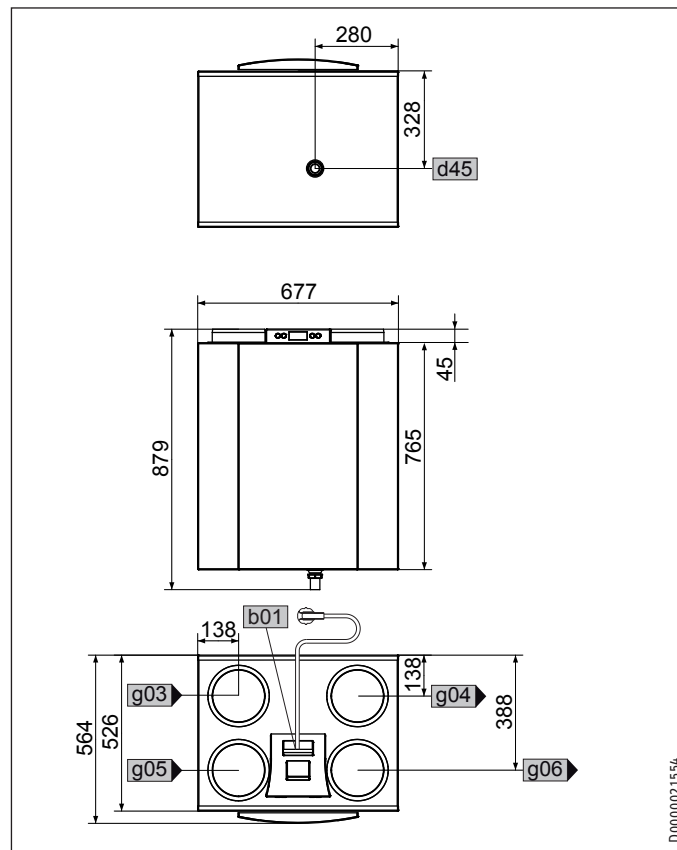

- Personal protective equipment
- Set of screwdrivers
- Set of spanners
- Combi pliers
- Stanley knife

16. Specification

16.1 Dimensions and connections



D0000021554

				LWZ 370 plus	LWZ 170 E plus
b01	Entry electrical cables				
d45	Condensate drain	Diameter	mm	32	32
g03	Outdoor air	Nominal diameter		DN 180	DN 160
		↓			
					
g04	Exhaust air	Nominal diameter		DN 180	DN 160
		↑			
					
g05	Extract air	Nominal diameter		DN 180	DN 160
		↑			
					
g06	inrushing air	Nominal diameter		DN 180	DN 160
		↓			
					

16.2 Minimum clearances

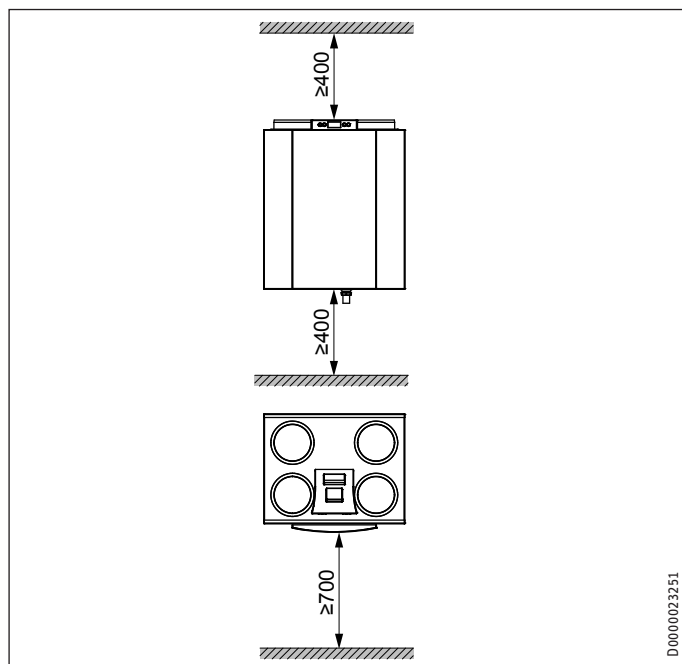

16.3 Data table

		LWZ 370 plus 232033	LWZ 170 E plus 233850
Sound emissions			
Sound power level L _{wa}	dB(A)	48	44
Energy data			
Energy efficiency class in average climates, manual control		A	A
Electrical data			
Rated voltage	V	230	230
Max. current consumption	A	6	6
Power consumption excl. preheating coil	A	0.7	0.5
Power consumption incl. preheating coil	A	6	6
Phases		1/N/PE	1/N/PE
Frequency	Hz	50	50
Power consumption	W	9 - 172	9 - 138
Power consumption excl. preheating coil	W	172	132
Power consumption incl. preheating coil	W	1380	1350
Versions			
IP rating		IP 30	IP 30
Filter class		ISO Coarse > 60 % (G4)	ISO Coarse > 60 % (G4)
Dimensions			
Height	mm	765	765
Width	mm	677	677
Depth	mm	567	567
Weights			
Weight	kg	38	38
Connections			
Air connector diameter	mm	180	160
Condensate connection	mm	32	32
Values			
Air flow rate	m ³ /h	50-400	50-300
Heat recovery level up to	%	90	90
Application range, extract air	°C	15-30	15 - 30
Max. ambient temperature	°C	60	60
Available external pressure, ventilation	Pa	160	160

Further details

		LWZ 370 plus 232033	LWZ 170 E plus 233850
Maximum altitude for installation	m	2000	2000

INSTALLATION Specification

16.4 Wiring diagram

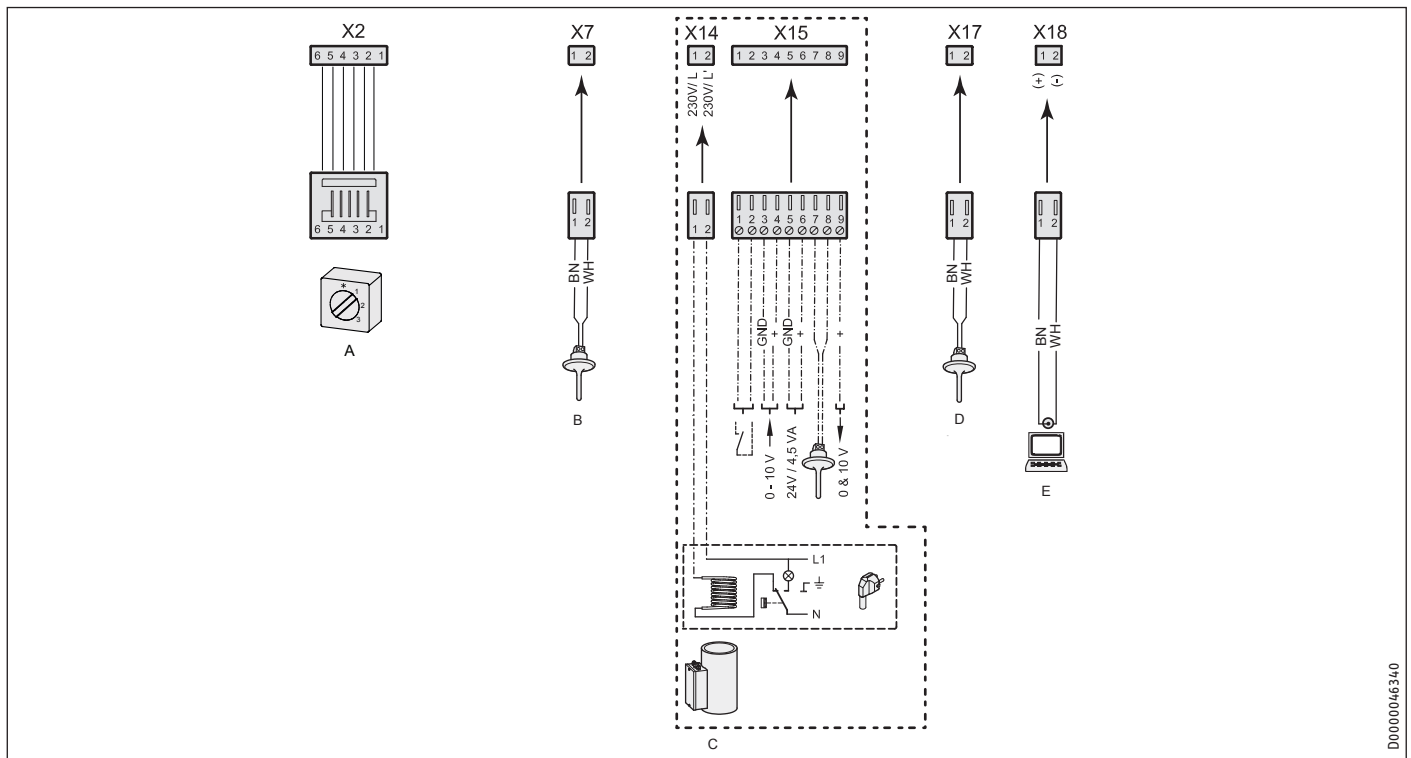

- A 3-stage switch, 4-stage switch, air quality sensor FEQ or remote control FEZ (see chapter "Installation / Electrical connection / Standard circuit")
- B Outside temperature sensor
- C Additional preheater coil
- D Room temperature sensor
- E Service connection

16.5 Sound

In practice, measuring tolerances mean that the value may deviate by 1 dB(A).

Sound power LWZ 370 plus

Ventilation rate [m ³ /h]		100		200		225		300			400		
Static pressure	Pa	9	40	38	80	47	100	84	175	240	150	225	
Sound power level L _w (A)	Appliance noise emission	dB(A)	29.5	32.5	40.5	41.5	43.5	47.5	51.0	53.0	54.0	54.5	57.0
	Exhaust air duct	dB(A)	31.5	34.5	46.5	48.0	48.5	50.0	56.5	57.0	58.0	59.0	60.0
	Outdoor air duct	dB(A)	42.5	47.5	57.0	59.0	60.5	62.5	66.0	68.0	69.5	70.5	71.5

Sound power LWZ 170 E plus

Ventilation rate [m ³ /h]		90		150		210		300		
Static pressure	Pa	50	100	50	100	50	100	50	100	
Sound power level L _w (A)	Appliance noise emission	dB(A)	30	33	38	38	44	46	50	52
	Exhaust air duct	dB(A)	33	34	39	42	45	46	54	54
	Outdoor air duct	dB(A)	44	47	52	55	60	60	67	67

INSTALLATION Specification

16.6 Fan diagram

LWZ 370 plus

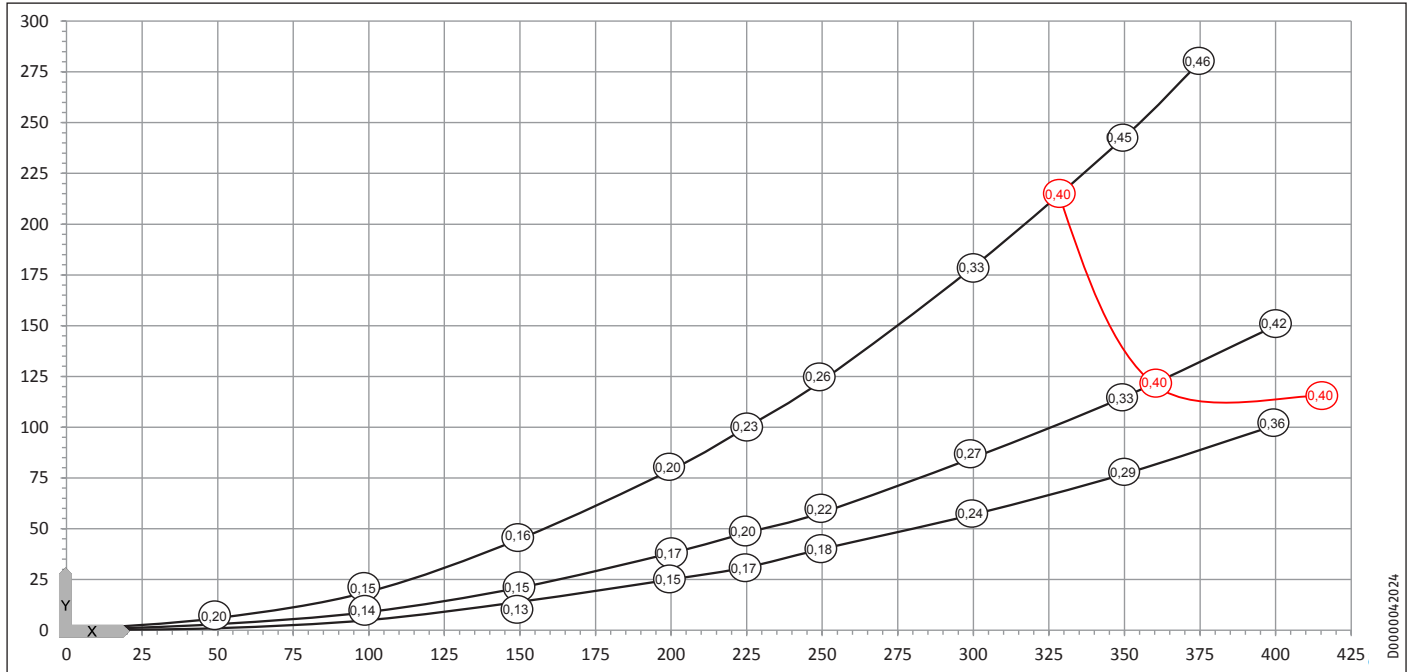

- X Air flow rate [m³/h]
- Y Average value, static pressure [Pa]
- (X) Power consumption of both fans [Wh/m³]

LWZ 170 E plus

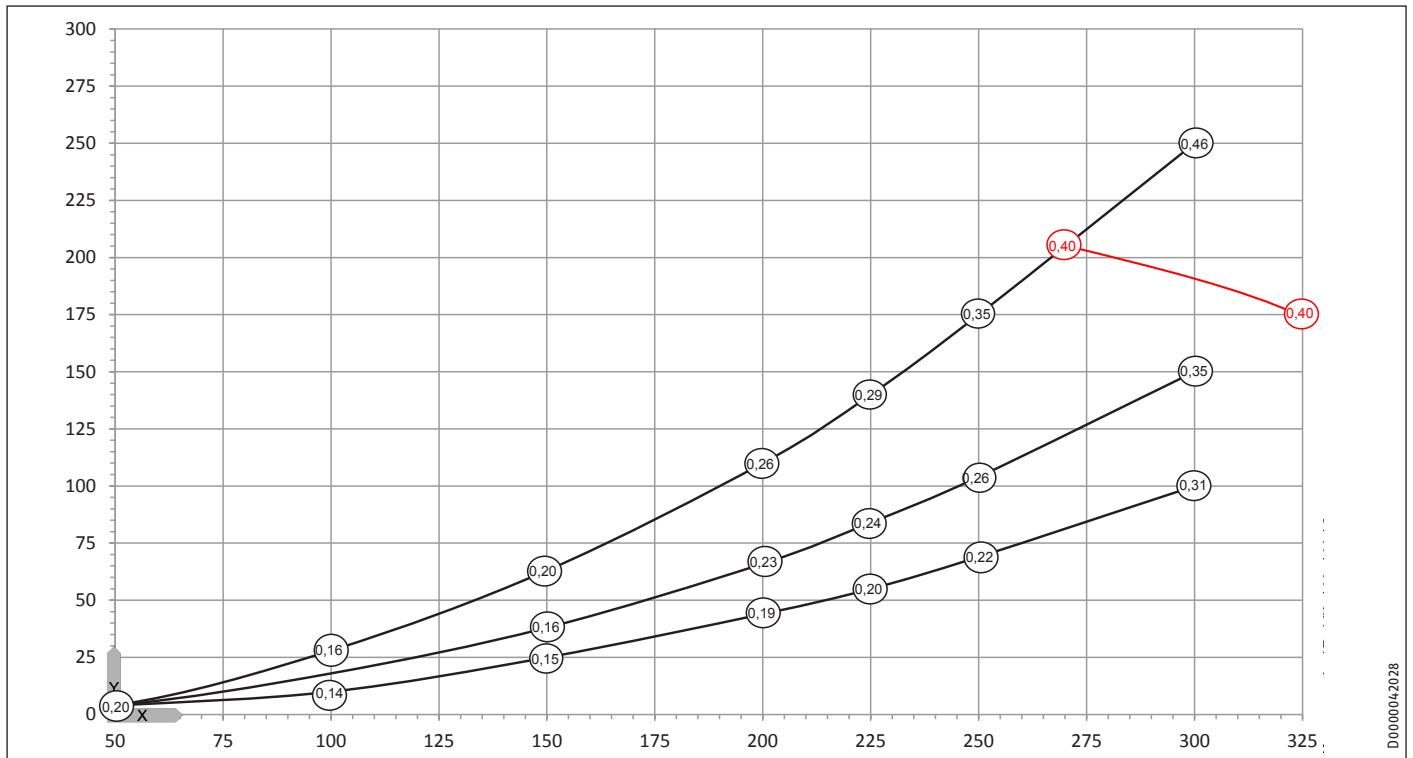

- X Air flow rate [m³/h]
- Y Average value, static pressure [Pa]
- (X) Power consumption of both fans [Wh/m³]

Guarantee

The guarantee conditions of our German companies do not apply to appliances acquired outside of Germany. In countries where our subsidiaries sell our products a guarantee can only be issued by those subsidiaries. Such guarantee is only granted if the subsidiary has issued its own terms of guarantee. No other guarantee will be granted.

We shall not provide any guarantee for appliances acquired in countries where we have no subsidiary to sell our products. This will not affect warranties issued by any importers.

Environment and recycling

We would ask you to help protect the environment. After use, dispose of the various materials in accordance with national regulations.

NOTES

Deutschland

STIEBEL ELTRON GmbH & Co. KG
Dr.-Stiebel-Straße 33 | 37603 Holzminden
Tel. 05531 702-0 | Fax 05531 702-480
info@stiebel-eltron.de
www.stiebel-eltron.de

Verkauf

Tel. 05531 702-110 | Fax 05531 702-95108 | info-center@stiebel-eltron.de

Kundendienst

Tel. 05531 702-111 | Fax 05531 702-95890 | kundendienst@stiebel-eltron.de

Ersatzteilverkauf

Tel. 05531 702-120 | Fax 05531 702-95335 | ersatzteile@stiebel-eltron.de

Australia

STIEBEL ELTRON Australia Pty. Ltd.
294 Salmon Street | Port Melbourne VIC 3207
Tel. 03 9645-1833 | Fax 03 9645-4366
info@stiebel.com.au
www.stiebel.com.au

Austria

STIEBEL ELTRON Ges.m.b.H.
Gewerbegebiet Neubau-Nord
Margaritenstraße 4 A | 4063 Hörsching
Tel. 07221 74600-0 | Fax 07221 74600-42
info@stiebel-eltron.at
www.stiebel-eltron.at

Belgium

STIEBEL ELTRON bvba/sprl
't Hofveld 6 - D1 | 1702 Groot-Bijgaarden
Tel. 02 42322-22 | Fax 02 42322-12
info@stiebel-eltron.be
www.stiebel-eltron.be

China

STIEBEL ELTRON (Tianjin) Electric Appliance
Co., Ltd.
Plant C3, XEDA International Industry City
Xiqing Economic Development Area
300085 Tianjin
Tel. 022 8396 2077 | Fax 022 8396 2075
info@stiebel-eltron.cn
www.stiebel-eltron.cn

Czech Republic

STIEBEL ELTRON spol. s r.o.
K Hájiřm 946 | 155 00 Praha 5 - Stodůlky
Tel. 251116-111 | Fax 235512-122
info@stiebel-eltron.cz
www.stiebel-eltron.cz

Finland

STIEBEL ELTRON OY
Kapinakuja 1 | 04600 Mäntsälä
Tel. 020 720-9988
info@stiebel-eltron.fi
www.stiebel-eltron.fi

France

STIEBEL ELTRON SAS
7-9, rue des Selliers
B.P 85107 | 57073 Metz-Cédex 3
Tel. 0387 7438-88 | Fax 0387 7468-26
info@stiebel-eltron.fr
www.stiebel-eltron.fr

Hungary

STIEBEL ELTRON Kft.
Gyár u. 2 | 2040 Budaörs
Tel. 01 250-6055 | Fax 01 368-8097
info@stiebel-eltron.hu
www.stiebel-eltron.hu

Japan

NIHON STIEBEL Co. Ltd.
Kowa Kawasaki Nishiguchi Building 8F
66-2 Horikawa-Cho
Saiwai-Ku | 212-0013 Kawasaki
Tel. 044 540-3200 | Fax 044 540-3210
info@nihonstiebel.co.jp
www.nihonstiebel.co.jp

Netherlands

STIEBEL ELTRON Nederland B.V.
Daviottenweg 36 | 5222 BH 's-Hertogenbosch
Tel. 073 623-0000 | Fax 073 623-1141
info@stiebel-eltron.nl
www.stiebel-eltron.nl

Poland

STIEBEL ELTRON Polska Sp. z O.O.
ul. Działkowa 2 | 02-234 Warszawa
Tel. 022 60920-30 | Fax 022 60920-29
biuro@stiebel-eltron.pl
www.stiebel-eltron.pl

Russia

STIEBEL ELTRON LLC RUSSIA
Urzhumskaya street 4,
building 2 | 129343 Moscow
Tel. 0495 7753889 | Fax 0495 7753887
info@stiebel-eltron.ru
www.stiebel-eltron.ru

Slovakia

TATRAMAT - ohrievače vody s.r.o.
Hlavná 1 | 058 01 Poprad
Tel. 052 7127-125 | Fax 052 7127-148
info@stiebel-eltron.sk
www.stiebel-eltron.sk

Switzerland

STIEBEL ELTRON AG
Industrie West
Gass 8 | 5242 Lupfig
Tel. 056 4640-500 | Fax 056 4640-501
info@stiebel-eltron.ch
www.stiebel-eltron.ch

Thailand

STIEBEL ELTRON Asia Ltd.
469 Moo 2 Tambol Klong-Jik
Amphur Bangpa-In | 13160 Ayutthaya
Tel. 035 220088 | Fax 035 221188
info@stiebel-eltronasia.com
www.stiebel-eltronasia.com

United Kingdom and Ireland

STIEBEL ELTRON UK Ltd.
Unit 12 Stadium Court
Stadium Road | CH62 3RP Bromborough
Tel. 0151 346-2300 | Fax 0151 334-2913
info@stiebel-eltron.co.uk
www.stiebel-eltron.co.uk

United States of America

STIEBEL ELTRON, Inc.
17 West Street | 01088 West Hatfield MA
Tel. 0413 247-3380 | Fax 0413 247-3369
info@stiebel-eltron-usa.com
www.stiebel-eltron-usa.com

STIEBEL ELTRON



Irrtum und technische Änderungen vorbehalten! | Subject to errors and technical changes! | Sous réserve d'erreurs et de modifications techniques! | Onder voorbehoud van vergissingen en technische wijzigingen! | Salvo error o modificación técnica! | Excepto erro ou alteração técnica | Zastrzeżone zmiany techniczne i ewentualne błędy | Omyly a technické změny jsou vyhrazeny! | A muszaki változtatások és tévedések jogát fenntartjuk! | Отсутствие ошибок не гарантируется. Возможны технические изменения. | Chyby a technické zmeny sú vyhradené! | Stand 9442